

DRAFT

1/2

GOVERNMENT OF BALOCHISTAN

**BALOCHISTAN COMMUNITY IRRIGATION
AND AGRICULTURE PROJECT**

BCIAP DESIGN MANUAL

PART 4: INFILTRATION GALLERIES

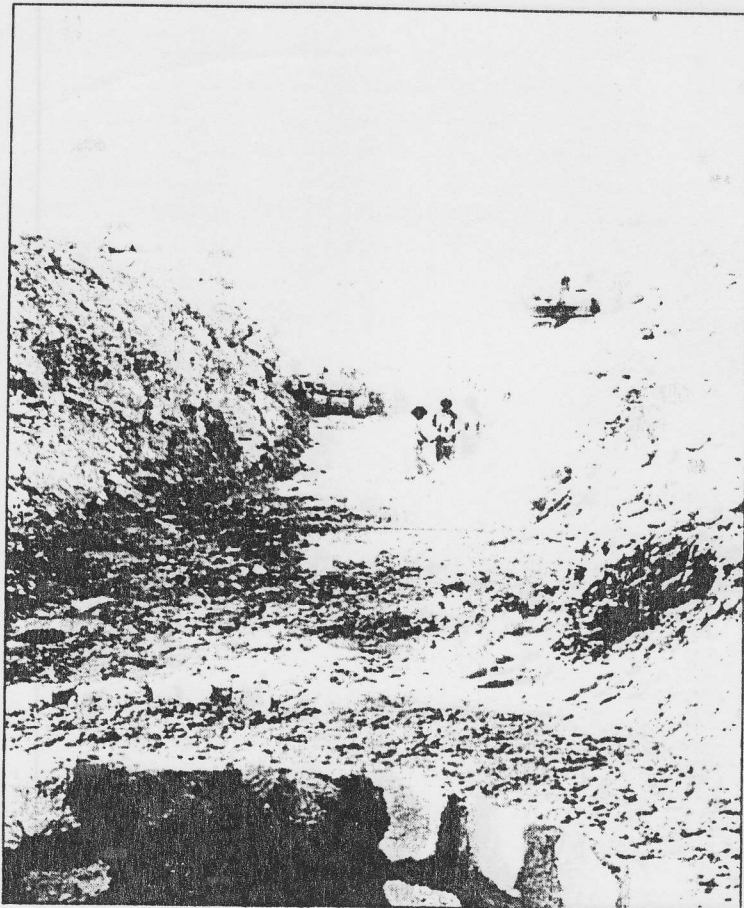

Construction of Kunara Infiltration Gallery

HALCROW - EUROCONSULT
NESPAK - TECHNO CONSULT
Technical Assistance Team
PO Box 255, Quetta, Balochistan

March 2002

GOVERNMENT OF BALOCHISTAN

BALOCHISTAN COMMUNITY IRRIGATION
AND AGRICULTURE PROJECT

BCIAP DESIGN MANUAL
PART 4: INFILTRATION GALLERIES

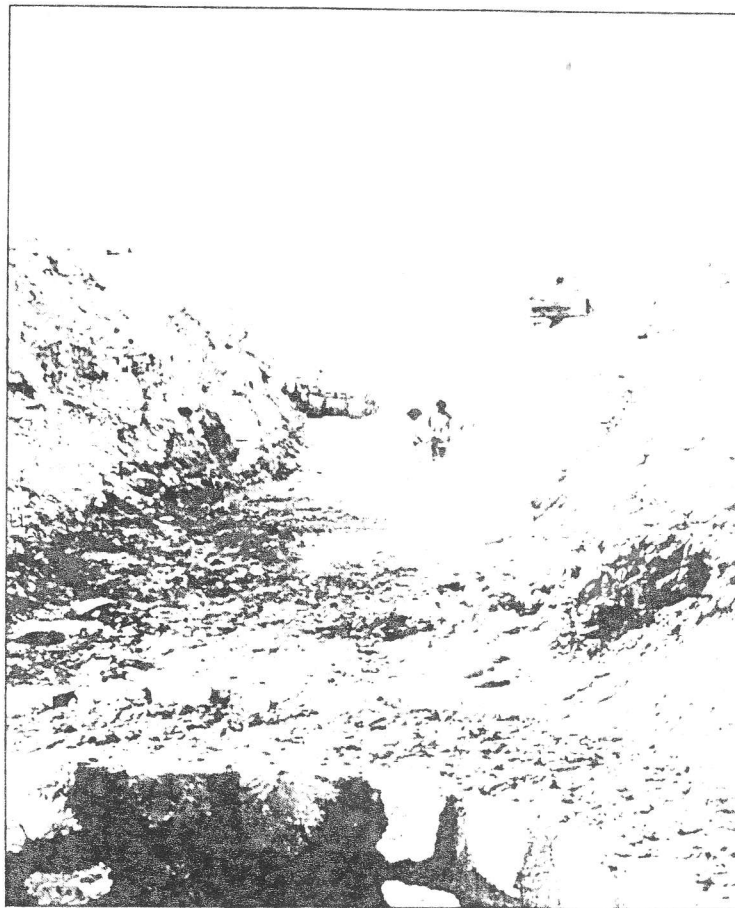

Construction of Kunara Infiltration Gallery

HALCROW - EUROCONSULT
NESPAK - TECHNO CONSULT
Technical Assistance Team
PO Box 255, Quetta, Balochistan

March 2002

GOVERNMENT OF BALOCHISTAN
BALOCHISTAN COMMUNITY IRRIGATION AND AGRICULTURE PROJECT

DESIGN MANUAL
PART 4 - INFILTRATION GALLERIES

TABLE OF CONTENTS

1	INTRODUCTION	1
2	GALLERY LOCATION AND ORIENTATION.....	5
2.1	Introduction	5
2.2	Command	5
2.3	River Stability.....	5
2.4	Water Depth, Depth to Rock and Scour Depth.....	6
2.4.1	Depth of Gallery.....	6
2.4.2	Scour Depth.....	6
2.5	Ownership of the Site.....	8
2.6	Gallery Orientation, Guide-bunds and Cut-offs.....	8
3	CONSTRUCTION METHODS.....	9
3.1	Introduction	9
3.2	Reinforced Concrete	9
3.3	Blockwork.....	9
3.4	Perforated Concrete Pipes.....	10
3.5	Galvanised Perforated Corrugated Steel Drainage Pipes.....	10
3.6	Gallery Access Manhole	10
3.7	Delivery Pipeline Manholes.....	11
3.8	Construction Sequence and Dewatering	11
4	HYDRAULIC DESIGN.....	17
4.1	Introduction	17
4.2	Surface Flows	17
4.2.1	Infiltration Rate.....	17
4.2.2	Filter Permeability.....	18
4.2.3	Slotted Area.....	18
4.2.4	Maintenance.....	18
4.3	Sub-surface Flows	19
4.4	Surface and Sub-surface Flows.....	21
4.5	Slot Location and Slotted Area.....	21
4.6	Outlet Pipeline/Conduit.....	22
5	FILTER DESIGN	27
5.1	General	27
5.2	Gallery Tapping Sub-surface Flow	27
5.3	Gallery Tapping Surface Flow.....	27
6	STRUCTURAL DESIGN	31
6.1	General	31
6.2	Roof	31
6.3	Walls	32
6.4	Floor.....	33
6.5	Outlet Gate.....	35
6.6	Outlet Pipe Bedding.....	35
6.6.1	Granular Bedding.....	35
6.6.2	Concrete Bedding.....	36

Appendix A Worked Example

Bibliography

GOVERNMENT OF BALOCHISTAN
BALOCHISTAN COMMUNITY IRRIGATION AND AGRICULTURE PROJECT

DESIGN MANUAL

CONTENTS OF OTHER PARTS

- Part 1 Site Investigations
- Part 2 Flood Estimation
- Part 3 Weirs
- Part 4 Infiltration Galleries
- Part 5 Irrigation Canals
- Part 6 Irrigation Structures
- Part 7 Flood Protection
- Part 8 Potable Water Supply Systems
- Part 9 Structural Design Criteria
- Part 10 Draughting Standards
- Part 11 Value Engineering
- Part 12 Standard Drawings

GOVERNMENT OF BALOCHISTAN
BALOCHISTAN COMMUNITY IRRIGATION AND AGRICULTURE PROJECT

DESIGN MANUAL

Conversion Factors

Length

1 inch	=	25.4 mm
1 foot (12 inches)	=	0.3048 m
1 mile (5280 ft)	=	1609 m

Area

1 ft ²	=	0.093 m ²
1 acre (43,560 ft ²)	=	0.4047 hectares (4047 m ²)
1 sq. mile (640 acres)	=	259 hectares

Volume

1 ft ³	=	0.028 m ³
35.315 ft ³	=	1 m ³

Weights

1 lb	=	0.454 kg
2.2 lb	=	1.0 kg
1 ton (US)	=	907.2 kg (0.907 tonnes)

Discharge

1 cusec (ft ³ /s)	=	0.028 cumecs (m ³ /s)
------------------------------	---	----------------------------------

1 INTRODUCTION

This Manual is based on the BMIADP Infiltration Gallery Design Manual. The Manual covers all aspects of infiltration gallery design and construction and this revised edition includes additional material based on the experience gained from constructing weirs in Balochistan under BCIAP.

An infiltration gallery is a perforated conduit constructed at depth in a river bed comprising permeable material. Infiltration galleries are designed to tap subsurface flow in the river gravels, or a combination of sub-surface and surface flow. However, if used to tap surface flow the filter media surrounding the gallery will quickly choke up, with fines, or organic growth. Galleries should therefore be used primarily to tap for sub-surface flow.

Infiltration galleries can either discharge their flow by means of a gravity discharge pipe or by pumping from a manhole at one end of the gallery. A general arrangement of a gallery is shown on **Figure 1.1**. If a gravity outlet from a gallery is to be used, then galleries will only be suitable when the site can command the land to be irrigated (refer Section 2.2 of Design Manual Part 2: Weirs).

Infiltration galleries are one of three methods used in Balochistan at present to abstract perennial flow from river beds, the other two being weirs and free intakes. Infiltration galleries are preferred over the other two alternatives in the following circumstances:

- where a free intake would be unreliable;
- where the construction of a gallery would be a cheaper method of abstracting sub surface or surface perennial flow than a weir; or
- where it is not possible to found a weir on impermeable material, the weir cannot intercept sub-surface flow. In such conditions, a gallery may be more effective. This is illustrated on **Figure 1.2**, which shows: (a) sub-surface flow passing underneath rather than over a weir; (b) an infiltration gallery constructed at intermediate depth in the river bed and only tapping part of the sub-surface flow; and (c) an infiltration gallery based on rock, tapping all the sub-surface flow.

The design of weirs and other structures which predominantly tap surface flows is fairly straight forward. However, the design of structures (such as infiltration galleries) to tap sub-surface flows is less straight forward, and site investigations are vital to determine the ground conditions and the sub-surface flow available (refer Design Manual Part 1: Site Investigations).

Even with comprehensive geotechnical and hydrological site investigations, when estimating design parameters, errors of the order of 10% to 30% may easily occur¹. While every care should be taken in the site investigations, this indicates that great accuracy in calculation is not required and in many cases a complicated method may be replaced by a simpler, less accurate one.

The design methods presented in this manual are simple solutions considered appropriate to Balochistan and sufficiently accurate to give acceptable results.

¹Huisman, L. "Groundwater Recovery." Macmillan, 1972.

Figure 1.1 TYPICAL ARRANGEMENT FOR AN INFILTRATION GALLERY

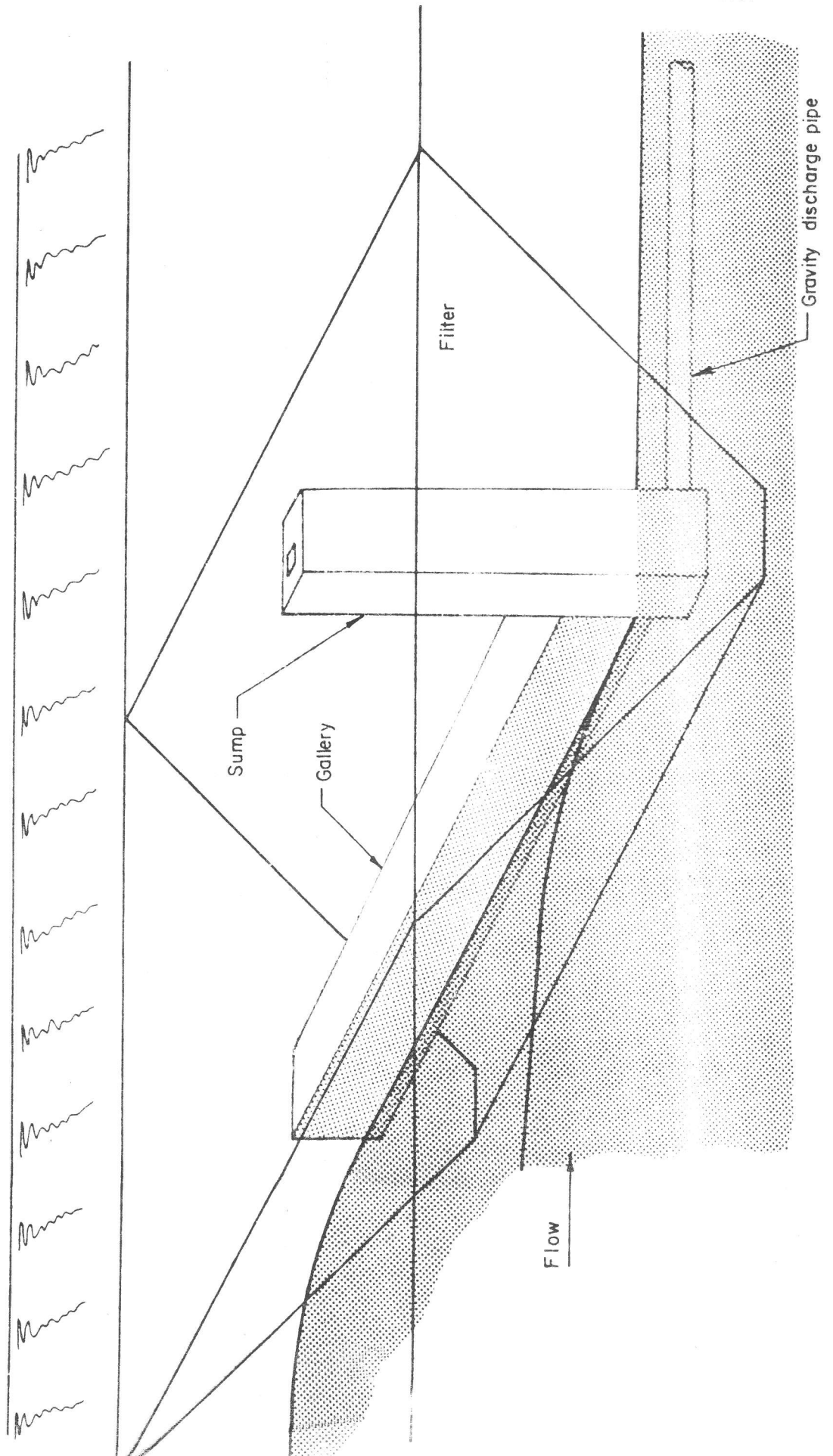
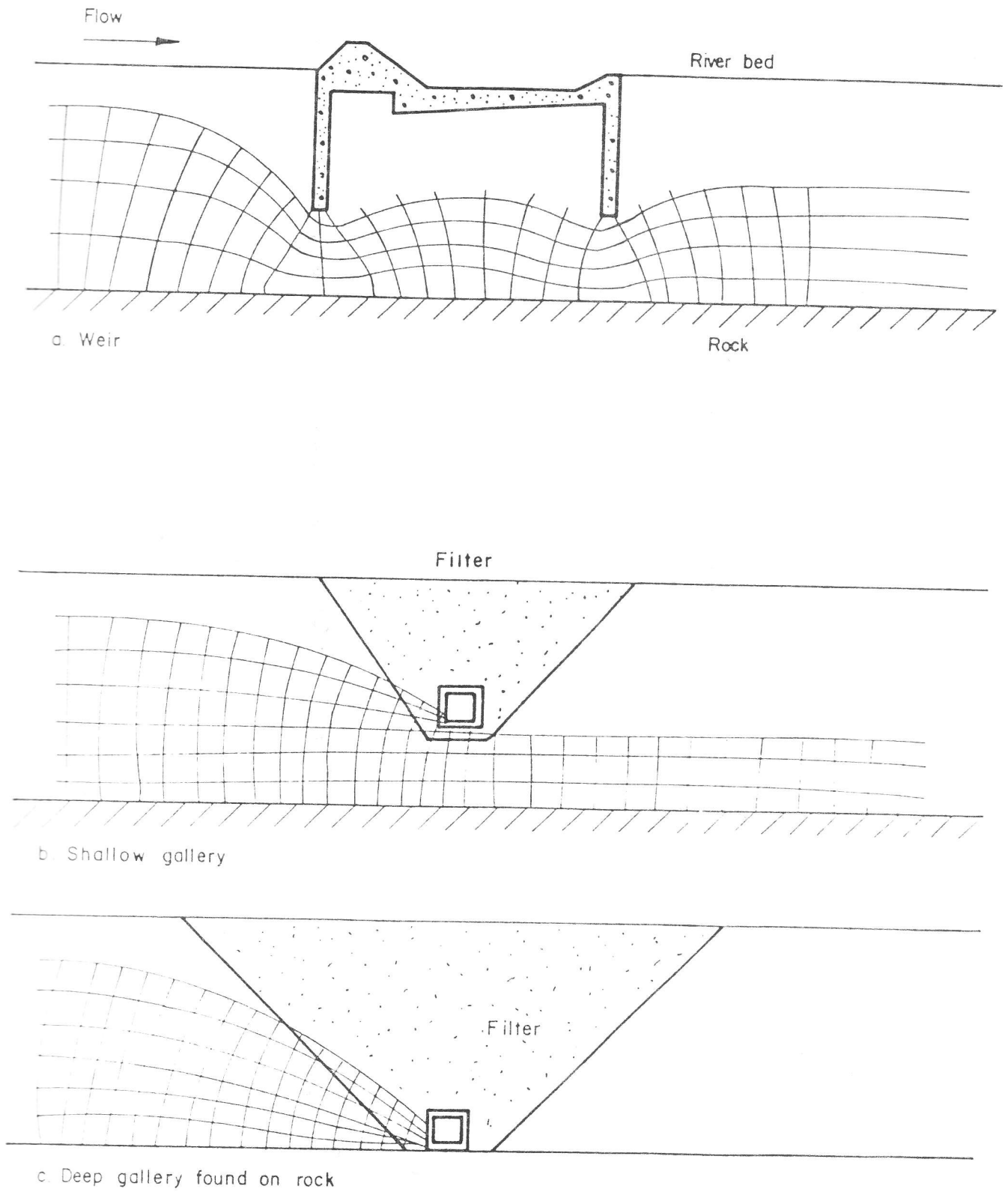

Figure 1.2 WEIR AND GALLERIES IN RIVER WITH DEEP DEPTH TO BED ROCK



2 GALLERY LOCATION AND ORIENTATION

2.1 *Introduction*

The location and orientation of an infiltration gallery will be affected by a number of features or factors. In most cases each of the features will have equal importance and the gallery site will have to be suitable to meet each of the criteria associated with these features. The main factors which affect the selection of the gallery site, the depth of the gallery and its orientation, and which are discussed in detail below, are:

- command;
- river stability;
- water depth, depth to rock and scour depth;
- ownership of the site; and
- orientation, guide-bunds and cutoffs.

When considering a proposed new gallery site, each of these factors must be considered. If the proposed gallery site does not meet all of the criteria then an alternative site should be sought. If a site cannot be found which satisfies all of the criteria, then a gallery should not be constructed and alternatives such as a free intake or a weir should be considered.

2.2 *Command*

It is rare, though not completely unknown, for farming communities to be prepared to take on the responsibility of operating a communal pumped irrigation system. An infiltration gallery should, therefore, normally be able to command the cultivated area by gravity. Obviously, this means that sufficient fall needs to be allowed for to ensure that the outlet pipeline/conduit and main channel can carry the design flow. The design of pumping installations is also therefore outside the scope of this Manual.

Chow⁴ recommends that all lined channels should have a minimum flow velocity of 2 to 3 ft/s when the percentage of silt present in the channel is small. If the minimum flow velocity in a lined channel is 2.5ft/s then vegetation growth will be largely prevented. In practice, very roughly, this means that for flows above 10 cusec, the channel slope must exceed about 0.001 and for smaller flows the channel slope must exceed about 0.002.

2.3 *River Stability*

An ideal gallery site would be one where the river is stable, neither meandering nor degrading nor aggrading.

Signs that a river is meandering are often clearly visible. The outside of bends will be being eroded and signs of river bank collapse are often visible. It is often possible to see how much a river has meandered by comparing the present position of a river with that shown on the 1:50,000 topographic maps of the Survey of Pakistan, which were last updated in about 1957.

Signs that a river bed is degrading (lowering) or aggrading (gradually being raised) are often more difficult to spot. Local people may say that the river level adjacent to an irrigation structure or inlet has been lowered such that the river no longer commands their lands. Conversely, the structure may be being buried by the river.

⁴ Chow, VT "Open Channel Hydraulics." McGraw-Hill, 1978.

Some river sites are obviously not meandering, such as where the river is confined between rock outcrops. Other sites are inherently unstable such as where rivers flow through alluvial plains and washout fans and braid into several channels. Here, not only can the channels move, but some channels can quickly become disused whilst the river cuts other channels for itself.

In practice, gallery's (like weirs) have to be constructed on a river which may meander to some extent. In there is a risk of this then stone protected guide bunds should be provided to ensure that the gallery is not by-passed in the future. Similarly, for a gallery an agrading river bed may be acceptable, whereas it will generally not be for a weir. A degrading river bed should be avoided as it poses an unacceptable risk of failure to the gallery structure.

2.4 Water Depth, Depth to Rock and Scour Depth

2.4.1 Depth of Gallery

The depth of the gallery will be determined by:

- the depth at which the maximum flow can be tapped;
- the depth to bedrock;
- the maximum depth to which excavation is practicable;
- the maximum depth at which command can still be achieved;
- the minimum depth to avoid scour problems; and
- the minimum depth to tap the sub-surface flow.

The preferred depth of the gallery will be determined by hydraulic considerations, these are discussed in detail in **Chapter 4**. However, the maximum depth will also be limited by considerations such as the depth of the permeable strata in the river bed and construction costs. Increases in the depth of a gallery increase the cost of the works through increased excavation for the gallery and pipeline and measures to de-water the gallery during construction. Also, the deeper the gallery, the longer the pipeline will probably have to be. The maximum depth of the gallery may also be dictated by problems of command

The principal factor affecting the minimum depth of the gallery is the need to avoid scour damage. This applies to the filter media around the gallery as well as the structure itself if the system is to remain fully functioning after the passage of each flood. It is common to construct galleries within the scour depth and protect the gallery and filter layers with gabion mattresses (refer Chapter 8: Flexible Protection of Design Manual Part 3: Weirs). Although this can work successfully, it is not recommended. In particular, if the filter media becomes clogged and needs to be replaced, removal of the gabion mattress protection is expensive and not practical.

2.4.2 Scour Depth

For the design flood in the river where a gallery is proposed, the Lacey empirical equation may be used to compute the depth of scour. The design scour depth below bed level (D) is given by:

$$\text{Design scour depth (D)} = XR - Y \quad [\text{metric units}]$$

Where:

X = scour factor dependent on type of reach (see Table 2.1 below)

Y = depth of flow [m]

R = $1.35 (q^2/f)^{1/3}$

q = the maximum discharge per unit width [m^2/s]

f = Lacey's silt factor

Table 2.1 Scour Factors

Type of Reach	Mean Value of Scour Factor "X"
Straight	1.25
Moderate bend (most transitions)	1.50
Severe bend (also Shank protection at spurs)	1.75
Right angled bend (and pier noses and spur heads)	2.00
Nose of Guide Banks	2.25

For channels where the bed material size is well known, the Lacey silt factor (f) may be calculated from the formula:

$$f = 1.76 \sqrt{D_{50}}$$

Where:

D_{50} = the sieve size through which 50% of the material passes by weight [mm].

Alternatively, the silt factor is given in **Table 7.2** below for various soil types.

Table 7.2 Lacey's Silt Factor

Soil Type	Lacey's Silt Factor "f"
Large boulders and shingle	20.0
Boulders and shingle	15.0
Boulders and gravel	12.5
Medium boulders, shingle and sand	10.0
Gravel and bajri	9.0
Gravel	4.75
Coarse bajri and sand	2.75
Heavy sand	2.0
Fine bajri and sand	1.75
Coarse sand	1.5
Medium sand	1.25
Standard silt	1.0
Medium silt	0.85
Fine silt	0.6
Very fine silt	0.4
Clay	5.0

2.5 Ownership of the Site

In Balochistan, the ownership of any proposed site for an infiltration gallery weir and the land through which the pipelines and channels to the command area will pass, must be clearly defined and undisputed. If the gallery site does not belong to either the benefiting community or to the Government, problems are likely to arise. Even if the community who own the gallery site and the beneficiaries are on good relations, the site owners will almost certainly use the situation to try and derive some benefit to themselves. If, on the other hand, the two communities have old rivalries, then it is most probable that the site owners will try to prevent the gallery from being constructed.

2.6 Gallery Orientation, Guide-bunds and Cut-offs

The BMIADP Infiltration Gallery Design Manual proposed three possible orientations/combinations for galleries. However, experience suggests that galleries are most successful when used to tap (mainly) sub-surface flow, and should extend over the full width of the river bed.

The reason for this is that the composition of river gravels can vary considerably across the width of a river and consequently, sub-surface flows tend to be concentrated along particular seams of coarser material. Successive floods passing down a river will scour and redeposit material in the river bed and as a result, the paths along which most of the sub-surface water flows can move from time to time. A gallery that is only constructed across part of the river risks being left dry over time.

Galleries can be orientated perpendicular to river (ie directly over the river bed), or at an angle. Straight across is cheaper, and galleries tapping sub-surface flow are usually aligned straight across. Galleries tapping surface flow may need a longer infiltration length, and may therefore be aligned at an angle across the river (see Section 4.2).

If the river bed is particularly wide, and flood and sub-surface flows are clearly concentrated in one part, then it may be cost effective to build a gallery in the main part, and provide stone protected guide bunds to ensure that the flood flows do not in the future out flank the gallery. Also, cut-offs may be provided under the guide bunds to prevent any sub-surface flow by-passing the gallery. These cut-offs may be concrete or a buried impermeable membrane.

3 CONSTRUCTION METHODS

3.1 Introduction

The advantages and disadvantages of four possible methods of constructing an infiltration gallery are discussed in this Chapter. The four methods are:

- RCC box culvert sections with slots or holes;
- box culverts with masonry walls and concrete top and bottom slabs;
- perforated concrete pipes; and,
- galvanized, perforated, corrugated, steel drainage pipes

Based on the experience of constructing galleries on BMIADP, the second option (block masonry walls with reinforced concrete (RCC) floor and pre-cast RCC roof slabs) is the recommended approach and standard details for this type of gallery are given in Part 12 of this Design Manual.

Galleries require to be cleaned periodically and the frequency of such cleaning will depend on the adequacy of the design of the filters and the slot sizes in the gallery. Galleries must therefore be designed for human access and it is recommended that a practical minimum size for a gallery is 4 ft high by 3 ft wide. If galleries are constructed using pipes, they should be between 3 ft and 4 ft in diameter.

The physical constraints on the location and depth of a gallery discussed here and in Chapter 2 mean that, besides gallery length, there are in practice only minor variations in the construction details of infiltration galleries.

3.2 Reinforced Concrete

BMIADP constructed three galleries as reinforced concrete boxes with either slots or holes in the sides formed by permanent shuttering. These structures proved easy to design had two distinct disadvantages in terms of construction:

- The reinforcement, permanent shuttering for the slots or holes and the main shuttering for the walls was difficult to assemble. The quantity of reinforcement and slots forms in the walls made placing concrete very difficult, resulting in honeycombing of the concrete and/or displaced slots where the contractor was over zealous in trying to compact the concrete.
- Because of the difficulties outlined above, the construction process was very slow. This resulted in increased dewatering costs for the contractor and also increased the risk of flood damage.

3.3 Blockwork

Constructing a gallery with blockwork walls, RCC floor and precast RCC roof slabs is considerably easier and quicker than the RCC box described above. Complicated formwork to form the slots is also avoided since the slots are made by leaving the vertical joints between the blocks unmortared.

Under BMIADP two galleries of this type were constructed. They were successful, and this type of construction was adopted for the new infiltration gallery constructed under BCIAP: Kunara 3. Details of the construction are shown on Figure 3.1 and Figure 3.2.

Where good easily squared stone masonry is locally available, this may be used for the side walls. However the stonework must be carefully dressed in order to ensure that the joints are

of uniform size so that the filter does not migrate through the walls. The preferred alternative is to construct the walls from precast concrete blocks. These should be made with a slight taper on the sides so that any particle of the filter which passes through the front edge of the blocks continues to migrate through the wall and does not become stuck in the wall. If this is not done, then the gallery slot would gradually become choked. The reinforced concrete cast in-situ concrete floor slab and the lip of the roof slab are designed to prevent the walls from being pushed inwards.

3.4 Perforated Concrete Pipes

A possible alternative to the box culvert approach could be using large (about 4 ft diameter) reinforced concrete pipes with slots cast into them. The pipes could be cast in short lengths at site and then lowered into the excavation. This would be about the fastest possible construction technique since almost no concrete work would be required in the river bed. If the pipes were about 4 inches thick and made in three foot sections then they would weigh about 0.45 tonnes each which could be easily handled on site.

3.5 Galvanised Perforated Corrugated Steel Drainage Pipes

Galvanised corrugated steel pipes have been used as culverts in many parts of the World including Balochistan. The pipes are supplied in half sections, 2 ft long, and are bolted together on site to form a culvert. The sections are also easy to handle on site as each section for a 5 ft diameter pipe only weighs about 180 lb. The manufacturers of these pipes can also produce the pipes ready perforated with $\frac{3}{8}$ inch holes, so that the pipes could be used to make an infiltration gallery. However, such pipes are not manufactured in Pakistan and would therefore have to be imported.

3.6 Gallery Access Manhole

Galleries are likely to require periodic cleaning, however well the filter has been designed. The gallery should therefore be provided with at least one manhole for easy access. A typical detail for such a manhole is shown on **Figure 3.3**. Important features for the manhole design include:

- The top of the manhole terminates above high flood level (HFL);
- The manhole is provided with a lockable cover to prevent children filling it with debris;
- The opening in the cover slab is large enough for a man to enter easily and for debris to be removed;
- Good step irons or a steel ladder are provided;
- A small sump is provided to catch debris flowing from the gallery before it enters the pipe; and
- A gate is provided on the outlet to the gallery sump. This will allow the pipeline to be drained before starting work on maintaining or unblocking it.

3.7 *Delivery Pipeline Manholes*

Manholes are required at intervals along the delivery pipeline to allow for inspection and cleaning/unblocking of the pipeline. For ease of access to the pipeline, it is recommended that the manholes be placed no more than 300 ft apart from each other. This is also the maximum practical spacing for rodding the pipelines. The minimum diameter of the pipeline itself should be 3 ft. This is in order to allow a man to crawl down the pipeline and clear any serious blockages - normally the result of roots entering the pipe.

Generally, the top of any manholes along the pipeline located in a river bed should be above the design high flood level. However, to reduce costs, a practicable alternative for a deep pipeline is for the manholes to be buried well below the river bed level. In this case, markers need to be placed along the river bank to show the location of the manholes.

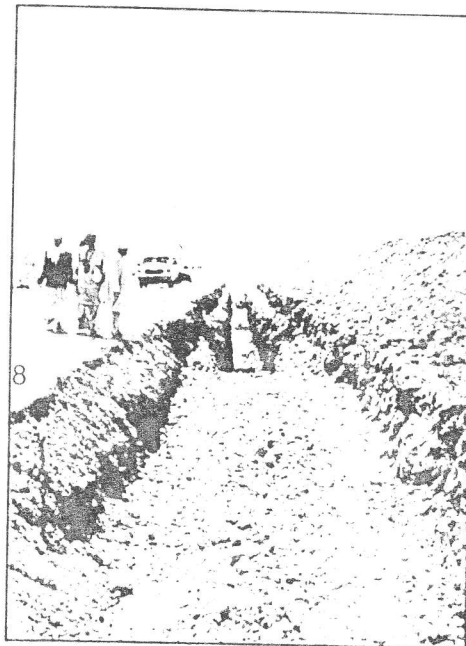

Laying RCC Delivery Pipeline

The roof slabs should have lockable access covers. 'Rocker' pipe sections should be provided either side of each manhole to facilitate differential settlement between the manhole and the pipeline.

3.8 *Construction Sequence and Dewatering*

The construction sequence and the method of dewatering the gallery excavation are important for the successful and efficient construction of an infiltration gallery. The timing of gallery excavation is critical. In Balochistan, while floods cannot always be predicted, within a given climatic region there are times of the year when floods are likely and times when they are not. Excavation for the gallery trench should be timed to start at the beginning of a dry season; not one month into it. This means that the contractor needs to mobilise his materials and equipment before the start of the dry season.

Similarly where part of the gallery is to be precast, then a sufficient number of units should be cast before excavation is allowed to start.

The construction of a gallery is an exercise in trying to achieve maximum progress while minimising risk. The risk of the excavation being damaged by a flood can be minimised by:

- Timely excavation;
- Speedy excavation; and
- Partial excavation.

Partial excavation means excavating the gallery trench in sections, say 200 feet at a time. If the site is therefore hit by a flood, only a portion of the excavation is damaged. Where hand labour is being used to excavate the trench, this construction sequence is easy. A section of trench can be dewatered and the gallery constructed whilst the next section of trench is being dug. When a section of gallery is completed it can be backfilled with filter and ordinary backfill whilst the next section of gallery is being built, and so on. For a large gallery, four gangs could therefore work simultaneously on precasting, excavating, gallery construction and backfilling respectively.

Where the excavation is to be undertaken by machine, the contractor may prefer to excavate the entire trench while he has the machine on site. In such cases, it is even more important that the contractor has sufficient labour and materials on site to allow the construction to proceed quickly within one season.

The main problem faced by a contractor in excavating for and constructing a gallery is groundwater. In most cases, the gallery will be being constructed in 15 ft of highly permeable river gravels and the excavation may be dewatered in one of three ways: pumping, gravity or a combination of these.

When pumping is to be used, a number of portable diesel or, where available, electric centrifugal pumps will be required. The capacity of the pumps should be about equal to the maximum discharge anticipated from the gallery. Additional standby pumps with a combined capacity of between 25% and 50% of the maximum discharge should also be available for use. The pumps will have to operate continuously for several months and they should therefore be new at outset and reliable. A comprehensive stock of spare parts should also be held on site and a good mechanic should be available at site. Care should also be taken to divert surface flows well away from the gallery excavation so that infiltration of this flow does not contribute to the flow having to be pumped.

An alternative to pumping may be a gravity trench constructed slightly deeper than the full depth of the gallery excavation. This trench is then lead down the river bed, at a shallower slope in the river bed, so that eventually the trench floor reaches the surface. For a 15ft excavation, in a river bed with a 1 in 100 slope (0.01) and assuming the gravity trench has a slope of just 1:500 (0.002), then the length of the trench would be 1,875ft ($15 / 0.008$)

Of course, the trench would have to be connected up to a sump in the gallery trench in order to keep the working area around the gallery completely dry. It may be possible to recover some or all of the cost of this trench if it can be taken along the same alignment as the proposed discharge pipeline. The trench would first be used for dewatering and then as the partially completed excavation for the discharge pipeline.

Where pumping is to be used for dewatering, a combined approach with gravity flow diversions can reduce pumping costs without the need for possible large scale excavation. Shallow groundwater may be intercepted by excavating a shallow trench upstream of the gallery trench and diverting the water away in the similar manner to gravity dewatering described above.

Figure 3.1 GENERAL ARRANGEMENT FOR A CONCRETE BLOCK MASONRY GALLERY

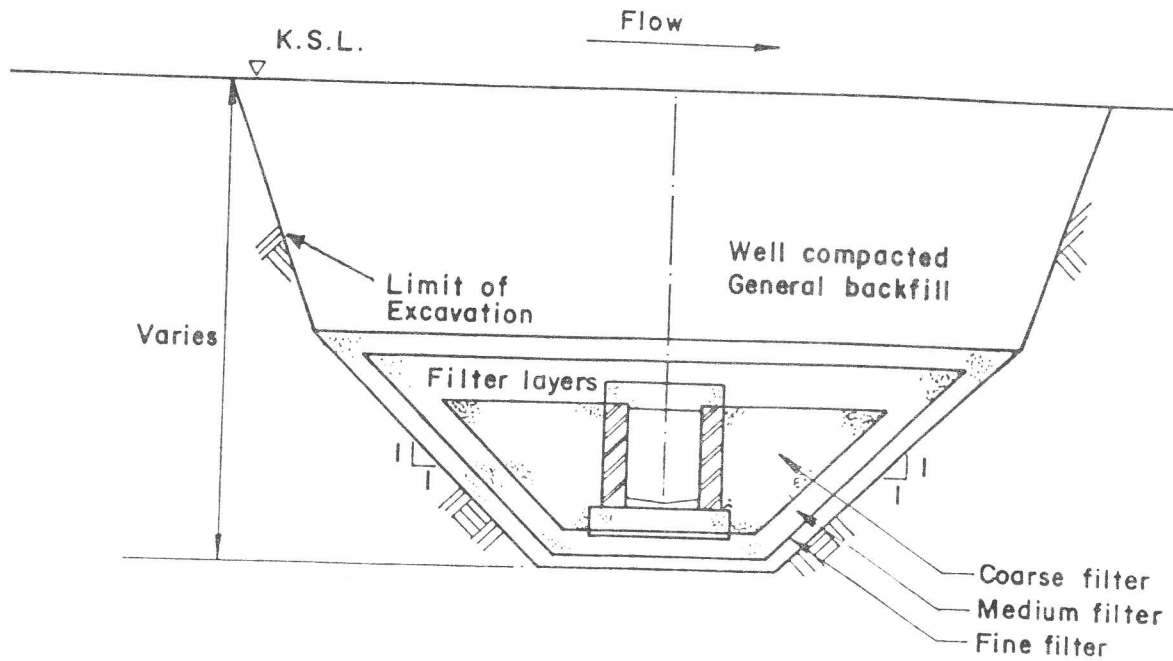

Reinforced concrete top slab see Figure II for Details

Vertical joints left open
All joints fully mortared

Reinforced concrete base slab on blinding layer

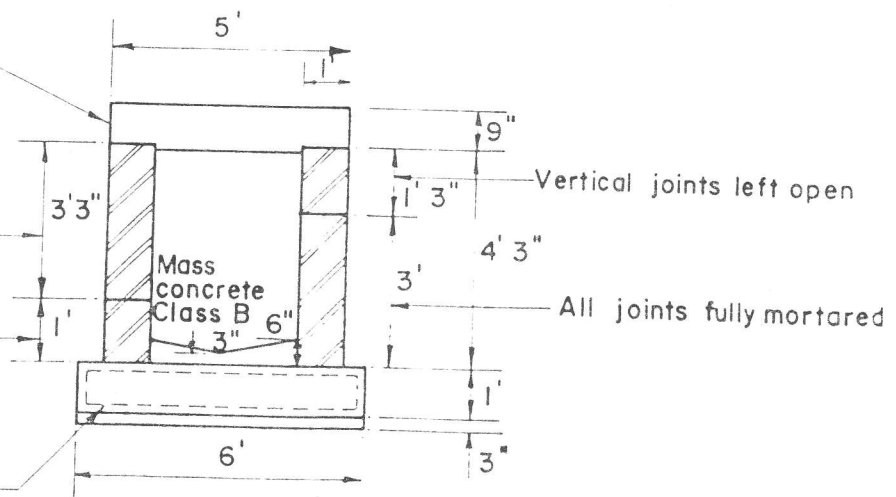
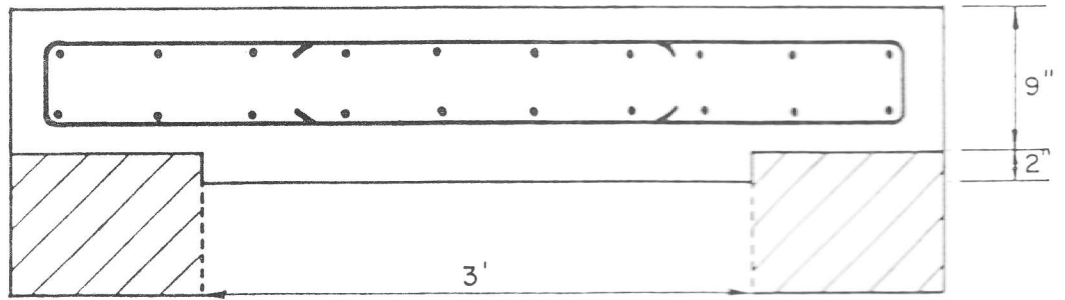
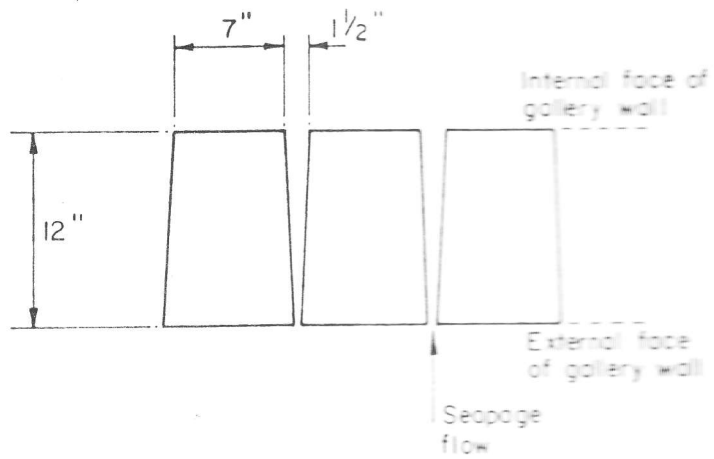

Figure 3.2 DETAILS FOR A CONCRETE BLOCK MASONRY GALLERY



DETAILS OF TOP SLAB



PLAN SECTION

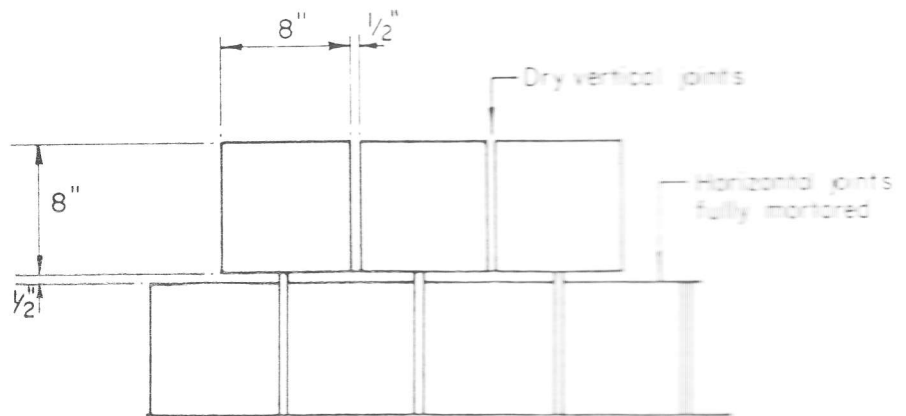

ELEVATION

DETAIL OF CONCRETE BLOCK WALLS

Figure 3.3 GENERAL ARRANGEMENT FOR A MANHOLE

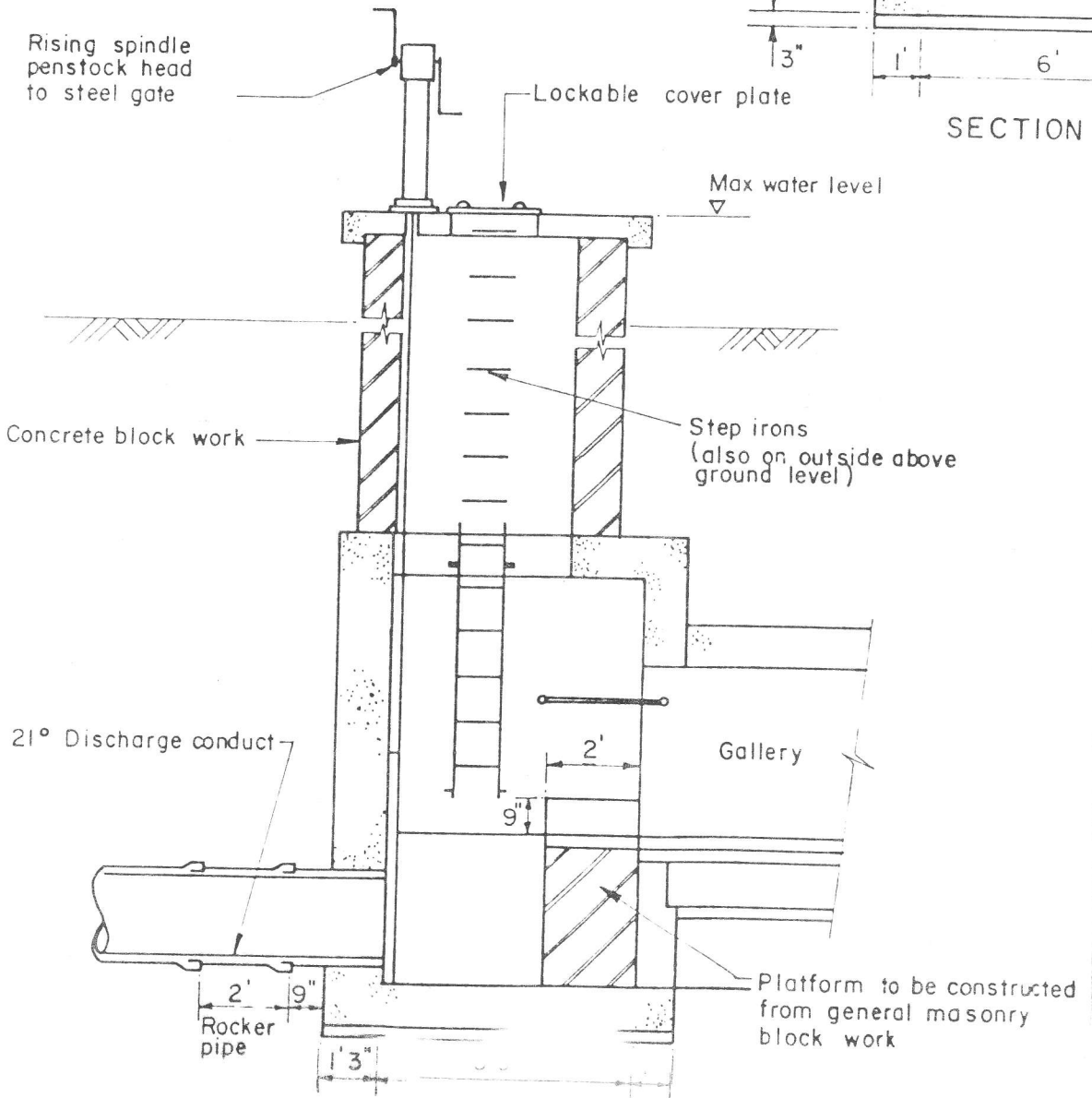
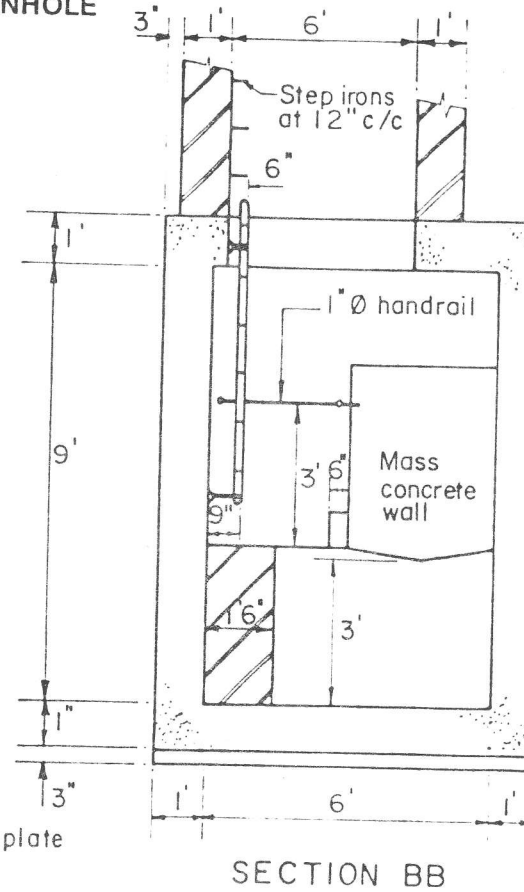
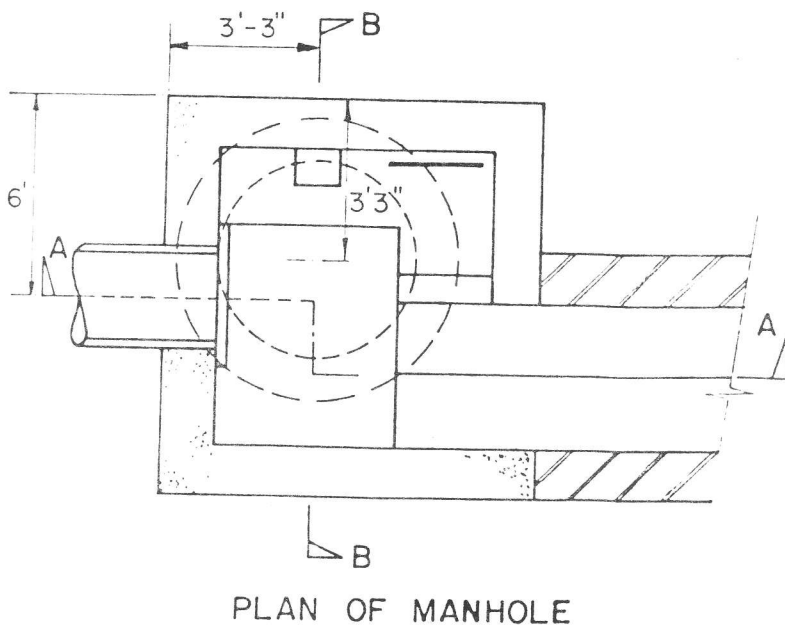

4 HYDRAULIC DESIGN

4.1 Introduction

Before the hydraulics of the flow to the gallery can be considered both the surface and sub-surface flow availability must have been determined, as must the physical characteristics of the river bed, as detailed in Part 1: Site Investigations.

This Chapter discusses how to calculate the amount of available surface and/or sub-surface flow that may be captured by galleries of different length, depth and slotted area. Only the steady state solutions of flow to galleries are dealt with, that is where the inflow is continuously abstracted from the gallery by means of a gravity discharge pipe or continuous pumping. Unsteady flow conditions arise when pumps are used intermittently to take water from a gallery. This system is not practised in Balochistan and is therefore not discussed here.

4.2 Surface Flows

Galleries tapping surface flows are usually placed diagonally across the river bed. The galleries are surrounded by highly permeable graded filters which may extend to the river bed level (see **Figure 4.1**). However, this should be avoided if possible.

The infiltration of the surface flow into the filter and into the gallery can be limited by any one of three possible factors:

- the infiltration rate from the river into the filter layer;
- the permeability of the filter; and
- the flow into the slots of the gallery.

To design a gallery and filter, each of the above conditions must be checked, to determine which is the limiting factor.

4.2.1 Infiltration Rate

For a simple approximation of the amount of infiltration, the infiltration rate measured on site (refer Part 1: Site Investigations) should be multiplied by the area of filter over which the perennial stream comes into contact. The area of contact is given by:

$$A = bB / \sin\theta$$

Where:

- B = width of perennial stream
- B = width of filter at the surface
- (θ) = angle of gallery to river bank ($= 90^\circ$ for a gallery straight across the river).

In practice, (θ) may vary from 90° to about 45° .

If the infiltration rate of the natural river bed material is high enough, the filter media surrounding the gallery can be kept below the scour level, and (gabion) protection is not required.

4.2.2 Filter Permeability

To determine the second factor, ie the rate of flow through the filter layer, the following equation⁴ may be used, where the symbols are shown on **Figure 4.2**:

$$L = \frac{Q \ln (2 d / r)}{2 \pi K H}$$

Where:

- L = The length of that portion of the gallery over which the flow will pass [ft]
- Q = The rate of discharge [ft³/s]
- d = The depth of the centre of the gallery below the river bed [ft]
- r = The radius of a circular gallery or the mean of half the depth and half the width of a rectangular gallery [ft]
- K = The permeability of the filter layer which may be estimated from the values given in Section 4.2 of Part 1: Site Investigations [ft/s]
- H = The depth of flow over the gallery [ft]

Overtime, filter permeability will reduce as the filter becomes choked with growth of micro-organisms, and/or with smaller particles carried with the river flow. Periodic replacement of the filter material is therefore required.

4.2.3 Slotted Area

As long as the gallery slotted area is in accordance with the recommendations given in **Section 4.5**, entry of flow into the gallery will not be a limiting factor, and the surface flow intercepted by a gallery will be the lower of the filter permeability and infiltration rate values discussed above.

4.2.4 Maintenance

Galleries tapping surface flow require regulator maintenance. For example, if the infiltration rate through the river bed material is not sufficiently high, then the filter media around the gallery needs to extend to river bed level, with gabions provided to prevent it being washed away. These gabions are vulnerable to flood damage and have a design life of only a few years. Once the gabions are damaged, the filter media will be washed away. Also, the filter media will become choked over time, requiring cleaning or replacement.

⁴

4.3 Sub-surface Flows

The flow to an interceptor drain or infiltration gallery from a sub-surface river or other source, has been described in detail by ILRI⁵.

Figure 4.3 (A) shows an infiltration gallery placed at part depth in a sloping river bed comprising alluvial material underlain by an impermeable layer. Since all inflowing groundwater originates from external sources upstream, we may apply Darcy's law and the flow per unit width is:

$$q_1 = K H \tan(x) \quad (\text{through cross section A}) \quad (\text{Eq. 4.2})$$

$$q_1 = K h_1 \tan(x + y) \quad (\text{through cross section B}) \quad (\text{Eq. 4.3})$$

Where:

- q_1 = the flow rate per unit width (ft²/s)
- K = permeability of the river bed material (ft/s)
- H = saturated thickness of flow beyond the influence of the gallery (ft)
- h_1 = water table height above the impervious layer (ft)
- $\tan(x)$ = slope of the impervious layer
- $\tan(y)$ = slope of the water table after installation of the gallery.

For small values of the angles x and y we may write with a fair approximation:

$$\tan(x + y) = \tan x + \tan y = \tan x + dh/dx \quad (\text{Eq. 4.4})$$

Substituting Equation 4.3 Into Equation 4.4 gives

$$q_1 = K h_1 (\tan x + dh/dx) \quad (\text{Eq. 4.5})$$

Equating Equations 4.2 and 4.5 and replacing h_1 by h gives, after rearranging:

$$\tan x \, dx = \frac{h}{H-h} \, dh \quad (\text{Eq. 4.6})$$

Integrating this equation with the boundary conditions $x = 0, h = D_0$, yields:

$$X = \frac{1}{\tan x} \left[H \ln \frac{(H-D_0)}{(H-h)} - (h-D_0) \right] \quad (\text{Eq. 4.7})$$

From Equation 4.7 it may be seen that, theoretically speaking, the drain has an infinite influence because we obtain an infinite value of x for $h = H$. If we assume, however, that the

⁵ ILRI "Design and Management of Drainage System" Volume 4 of International Institute for Land Reclamation and Improvement Publication No 20 "Drainage Principles and Applications." Wageningen, The Netherlands. 1980.

distance corresponding to $h = 0.9H$ to be the effective distance over which the drain exerts a significant drawdown, we can write, taking $D_0 = a.H$:

$$X_{eff} = \frac{H}{\tan x} \left[\frac{\ln(1-a) - (0.9-a)}{(H-h)} \right] = b H / (\tan x) \quad (\text{Eq. 4.8})$$

The following values of b , for increasing values of a have been calculated:

A	0.0	0.1	0.2	0.3	0.4	0.5	0.6	0.7	0.8	0.9
B	1.40	1.40	1.38	1.35	1.29	1.21	1.09	0.90	0.59	0.00

It is apparent from these values that for a drain installed so that $D_0 < 0.5H$, we may write, with some approximation, for the effective distance of drawdown up-slope:

$$X_{eff} = 1.33 H / (\tan x) \quad (\text{Eq. 4.9})$$

The drawdown down-slope equals approximately the height of water in the gallery and provided the radial resistance is negligible:

$$h_2 = D_0 \quad (\text{Eq. 4.10})$$

The discharge of the gallery, per unit of length, can then be expressed as:

$$q \, dr = q_1 - q_2 = \frac{(H-h_2)}{H} q_1 \quad (\text{Eq. 4.11})$$

Where:

$$\begin{aligned} q_1 &= KH \tan x = \text{discharge upstream per unit length} \quad [\text{ft}^2/\text{s}] \\ q_2 &= Kh_2 \tan x = \text{discharge downstream per unit width} \quad [\text{ft}^2/\text{s}] \end{aligned}$$

If the radial resistance is low, then $h_2 = D_0$, and: therefore:

$$q \, dr = \frac{(H-D_0)}{H} q_1 \quad (\text{Eq. 4.12})$$

The rate of flow from the gallery may then be calculated by multiplying the rate of flow per unit length by the length of the gallery. Where the permeability varies significantly across the river bed, then Equation 4.12 should be applied to the various sections of the river bed individually and then the discharge into each section calculated and the discharges summed to get the flow from the gallery.

Equation 4.12 is only valid if the radial resistance from the gallery is low, which will usually be the case if the gallery is surrounded by a highly permeable filter and the open area of the gallery is designed as recommended in Section 4.5. If, however, the radial resistance is high and cannot be neglected, a part of the water passing under the drain/gallery returns, as is shown on Figure 4.3 (B). To the upstream side of point P (the point where the water level attains its maximum level), water flows back towards the gallery, whereas to the downstream

side it flows down-slope. Equations 4.9 and 4.10 above are equally valid, provided that h_2 is greater than D_0 . If the radial resistance has to be taken into account, computer models are required to determine the shape of the water table.

The above two-dimensional theory applies well to a gallery in a restricted river bed, such as where the river is passing through a rock gorge and is confined on both sides. Where a river is situated in a wide alluvial plain then flow may well be passing through the alluvial material on both sides of the river as well as in the river bed itself. Where the site investigations show this to be the case, an approximation as to the amount additional flow the gallery may collect, due to the edge effects, may be determined by plotting a flow net in plan of the flow to the gallery, as shown on **Figure 4.4**. This type of flow net is difficult to plot manually but is amenable to computer solutions. On **Figure 4.4**, the flow net shows that the effective length of the gallery of length L is L' , and it is the length L' which should be used in computing the flow from the gallery in the above equations.

4.4 *Surface and Sub-surface Flows*

Some galleries will be designed to tap both surface and subsurface flows. Where this is the case then the hydraulics of flow through the filter may be undertaken independently and then the two flows added together to get the total flow from the gallery. This is a satisfactory approximation, since the flows take place in different areas of the filter. However, when calculating the area of slots required to be placed in the gallery, the combined surface and sub-surface flows must be used.

4.5 *Slot Location and Slotted Area*

The location of the slots in a gallery and the open area to be provided will depend on the required rate of flow into the gallery, the orientation of the gallery, how the flow will enter the gallery, allowances for the flow in the gallery to pass along the gallery, and the structural integrity of the gallery.

In order to ensure that the entry losses into the gallery are small, it is recommended⁶⁾ that the entrance velocity into the slots is limited to a maximum of 0.1 ft/sec. It is further suggested that this velocity should be achieved with 50% of the area of the slots blocked. The width of the slots should be a maximum of 1 inch and should correspond with the design of the innermost layer of the filter material so that the filter material cannot migrate into the slots.

When designing the layout of the slots, the structural integrity of the gallery must be taken into account. In order to achieve this, the open area of the slot may not exceed 6% of the area of the walls of the gallery. Where the 6% limit means that gallery cannot accept the whole design flow as calculated in **Section 4.2** and/or **Section 4.3** whilst maintaining recommended maximum entrance velocities, then the gallery must be lengthened.

Where a gallery has been assumed to have low radial resistance, then all the slots required to accommodate the design flow must be made in the upstream face of the gallery. It may however still be worth placing some slots in the downstream wall though these will, in theory, only come into operation should the upstream filter and slots become blocked. The lower part of both side walls should be left unslotted, in order to form a channel inside the gallery for the flow to pass along the gallery to the discharge point. If a gallery is being designed to tap surface flows, then the slots may be provided in the roof of the gallery as well as the sides.

⁶⁾ Bennett, TW "The Design and Construction of Infiltration Galleries." *Groundwater* Vol 8, No 3, 1970

4.6 *Outlet Pipeline/Conduit*

As discussed in **Section 3.7**, the minimum size of the pipeline should be set according to the requirements for maintenance and repair of the pipeline. However, the hydraulic capacity of the pipeline should also be checked. Ideally, this should be done using the Colebrook-White equation⁷. Manning's equation may be used but only if the designer is confident that the pipeline will not be running full.

Given the inaccuracies of the methods of determining the sub-surface flows and the anticipated flow from a gallery, it is recommended that the discharge system be designed for 25% greater than the anticipated maximum flow from the gallery. This will not significantly increase the cost of the system but will allow for the scheme to take advantage of higher than anticipated flows.

⁷/

Figure 4.1 CROSS SECTION THROUGH A GALLERY TAPPING SURFACE FLOW

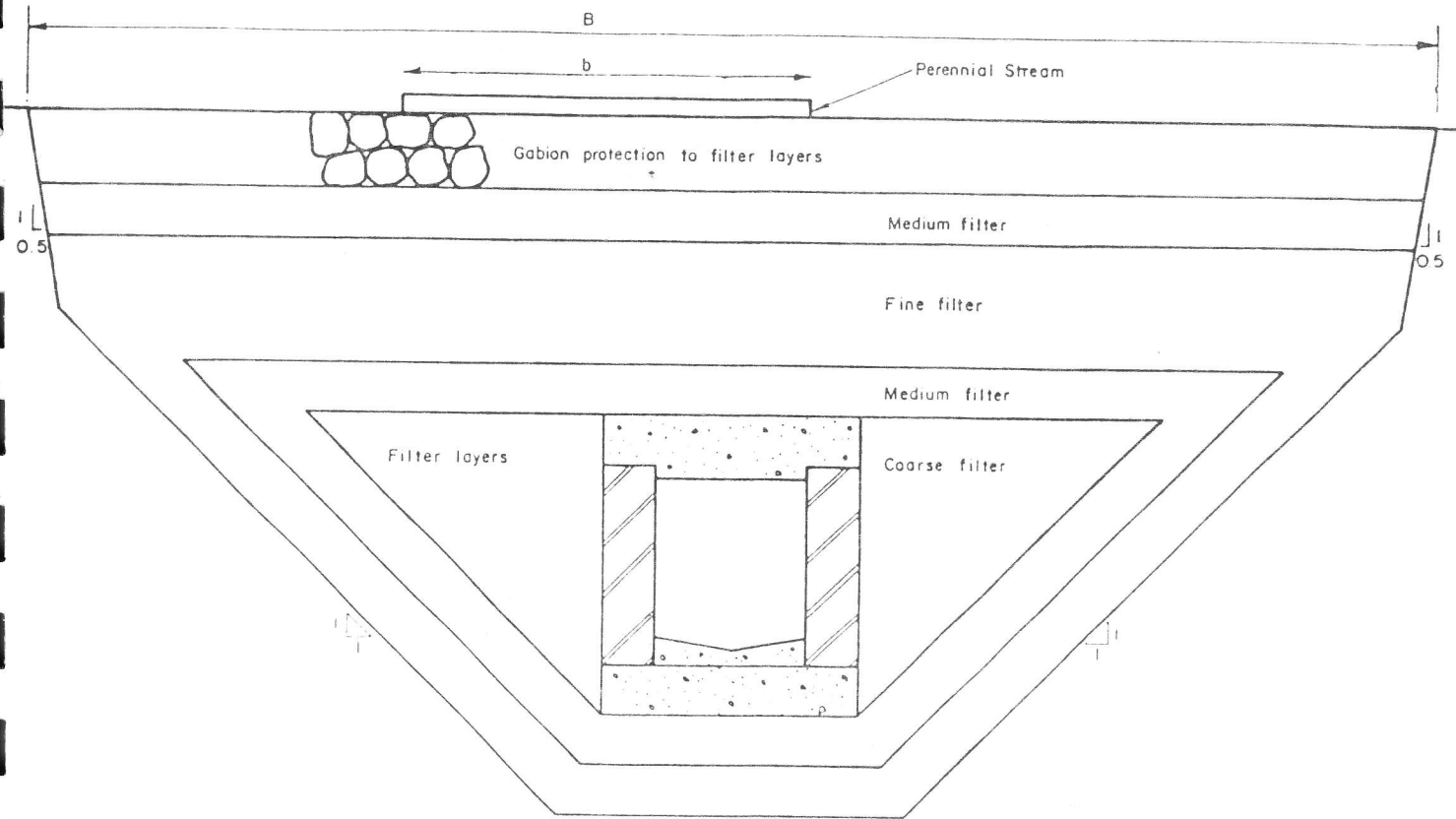

Figure 4.2 SURFACE FLOW INFILTRATION TO A GALLERY

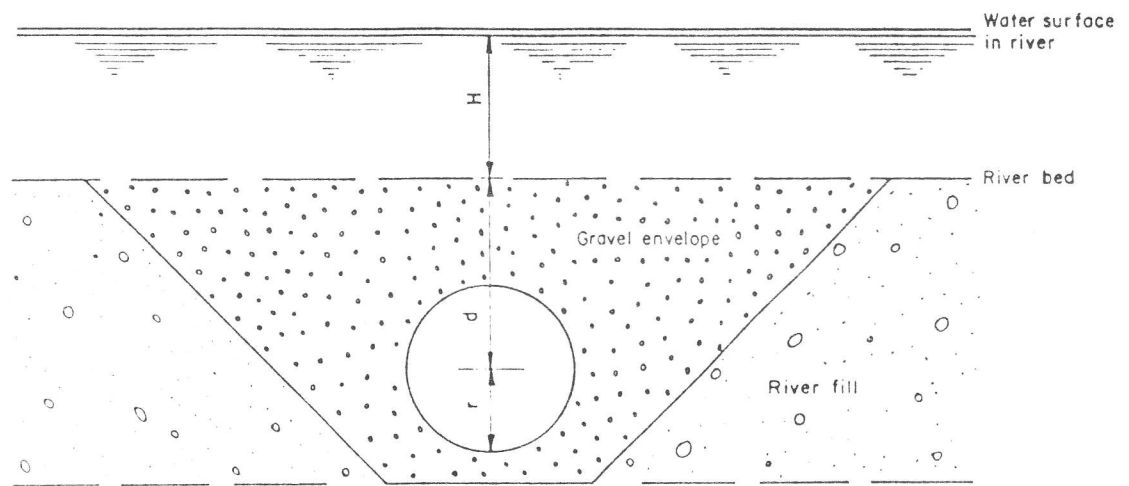

Figure 4.3(A) SUB-SURFACE FLOW TO A GALLERY

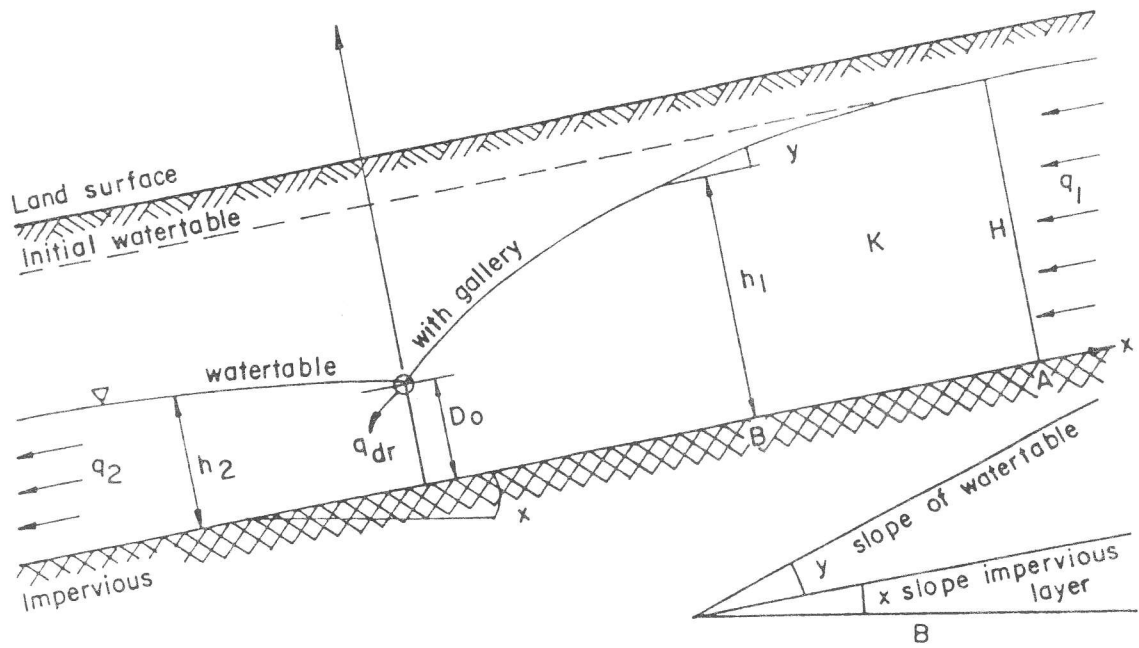

Figure 4.3(B) FLOW TO A GALLERY WITH HIGH RADIAL RESISTANCE

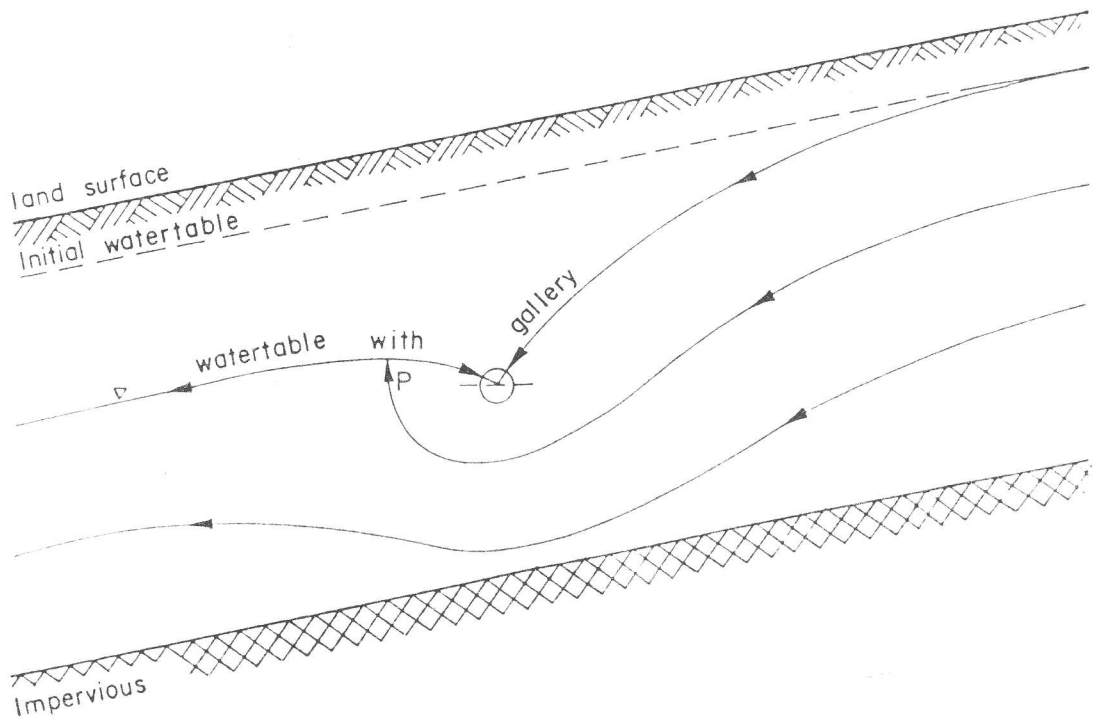
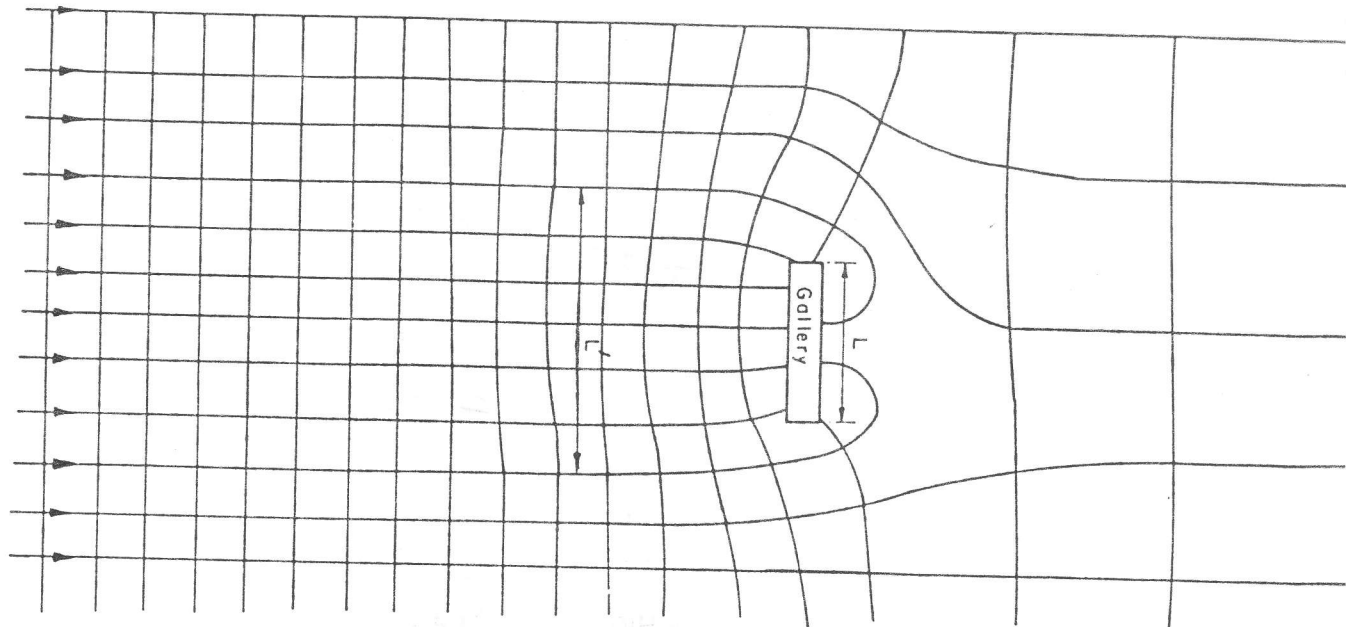
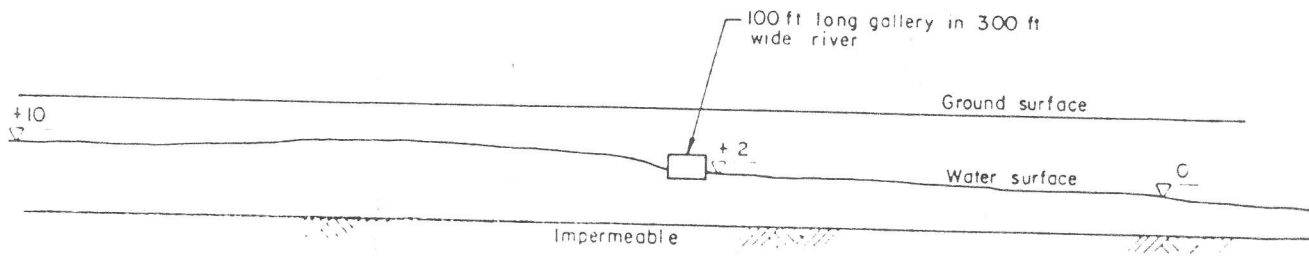

Figure 4.4 FLOW NET FOR A GALLERY IN A WIDE ALLUVIAL PLANE



FLOW NET PLAN



ELEVATION

5 FILTER DESIGN

5.1 General

Galleries must be surrounded by a graded filter; usually comprising several layers. The filters are designed to provide a highly permeable surround to the gallery, to ensure minimum hydraulic resistance for the flow entering the gallery and to prevent material from the river bed migrating towards and entering the gallery.

5.2 Gallery Tapping Sub-surface Flow

For a gallery tapping subsurface flow, the pattern of the filter layers is usually as shown on **Figure 5.1**. The finest layer of the filter is placed outermost and the coarsest innermost, ie the permeability increases inwards. The gradation of the filter layer or layers forming the inverted filter should conform to the following rule, established originally by Terzaghi:

$$\begin{aligned}d_{15} \text{ filter} / d_{85} \text{ soil} &< 5; \\d_{15} \text{ filter} / d_{15} \text{ soil} &> 5; \text{ and} \\d_{50} \text{ filter} / d_{50} \text{ soil} &< 25\end{aligned}$$

Where d_{85} is the sieve size which will pass 85% of the material, and similar for other percentages (d_{15} and d_{50}).

The above criteria relate respectively to:

- stability (ie preventing the movement of soil particles into the filter);
- permeability; and,
- uniformity.

When plotted on a grading graph, as shown on **Figure 5.2**, the grading curve of the filter should be sensibly parallel to that of the underlying soil. The filter should also contain less than 5% of material that will pass the number 200 sieve (0.074 mm).

For the inner layers of the filter, the layer should be designed using the above criteria, but substituting the grading of the outer filter for that of the "soil". For the innermost layer, the grading must also be coarse enough to prevent material passing into the slots of the gallery, to ensure this, the following rules should be adhered to:

$$\begin{aligned}d_{85} \text{ filter} / \text{slot width} &> 2 \\d_{10} \text{ filter} &\text{ should be greater than the slot size.}\end{aligned}$$

The minimum thickness of each filter layer should be 10 inches.

5.3 Gallery Tapping Surface Flow

Galleries tapping surface flow are vulnerable to the filters being scoured away, and should be avoided if possible. However, if a gallery is designed to tap surface flow, the filter layers should usually reach up to the river bed, as shown on **Figure 4.1**. The filter is protected either by gabion mattresses or stone riprap or concrete blocks.

- USBR⁴⁷ recommends the following formula for determining the size of rip-rap that will not be dislodged under turbulent flow conditions:

⁴⁷ USBR "Hydraulic Design of Stilling Basins and Energy Dissipators" United States Bureau of Reclamation, 1983.

$$D_{50} = (V_{av} / 4.915)^2 \quad (\text{turbulent flow conditions}) \quad [\text{metric units}]$$

Where:

- V_{av} = average velocity of flow for maximum discharge [m/s]
 D_{50} = average stone size [m]

The specific gravity of the stones was assumed to be 2.65 (ie density of 2,650kg/m³). If less dense stone is used, then the stone size should be increased correspondingly.

The grading of the rip rap should be as follows:

- Maximum stone size = 1.5D₅₀
- Minimum stone size = 0.5D₅₀
- Not more than 40% of the stone should be smaller in size than D₅₀

The thickness of the rip-rap layer should be at least 1.5 times the stone D₅₀ size.

If uniform sized concrete blocks, which have a specific gravity of 2.2, are used, then the weight of each concrete block should be at least 1.5 times the weight (about 1.8 times the size) of the D₅₀ size rip-rap stone. A lifting "eye" should be incorporated in each block during pre-casting to facilitate lifting and placing.

Figure 5.1 GENERAL ARRANGEMENT OF FILTER LAYERS

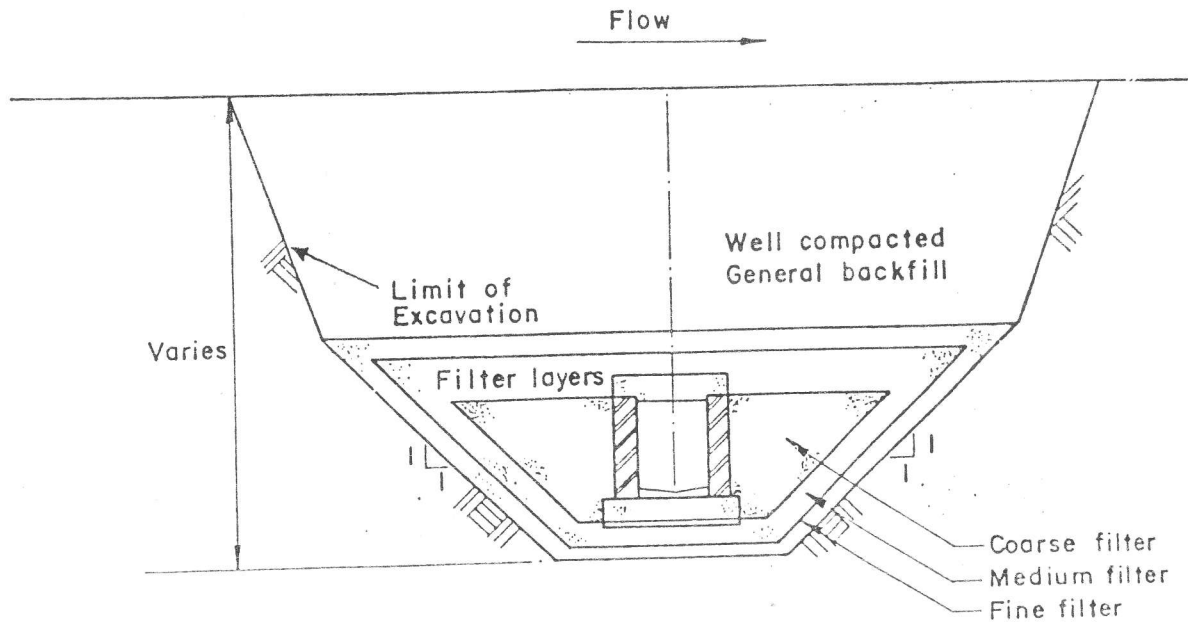
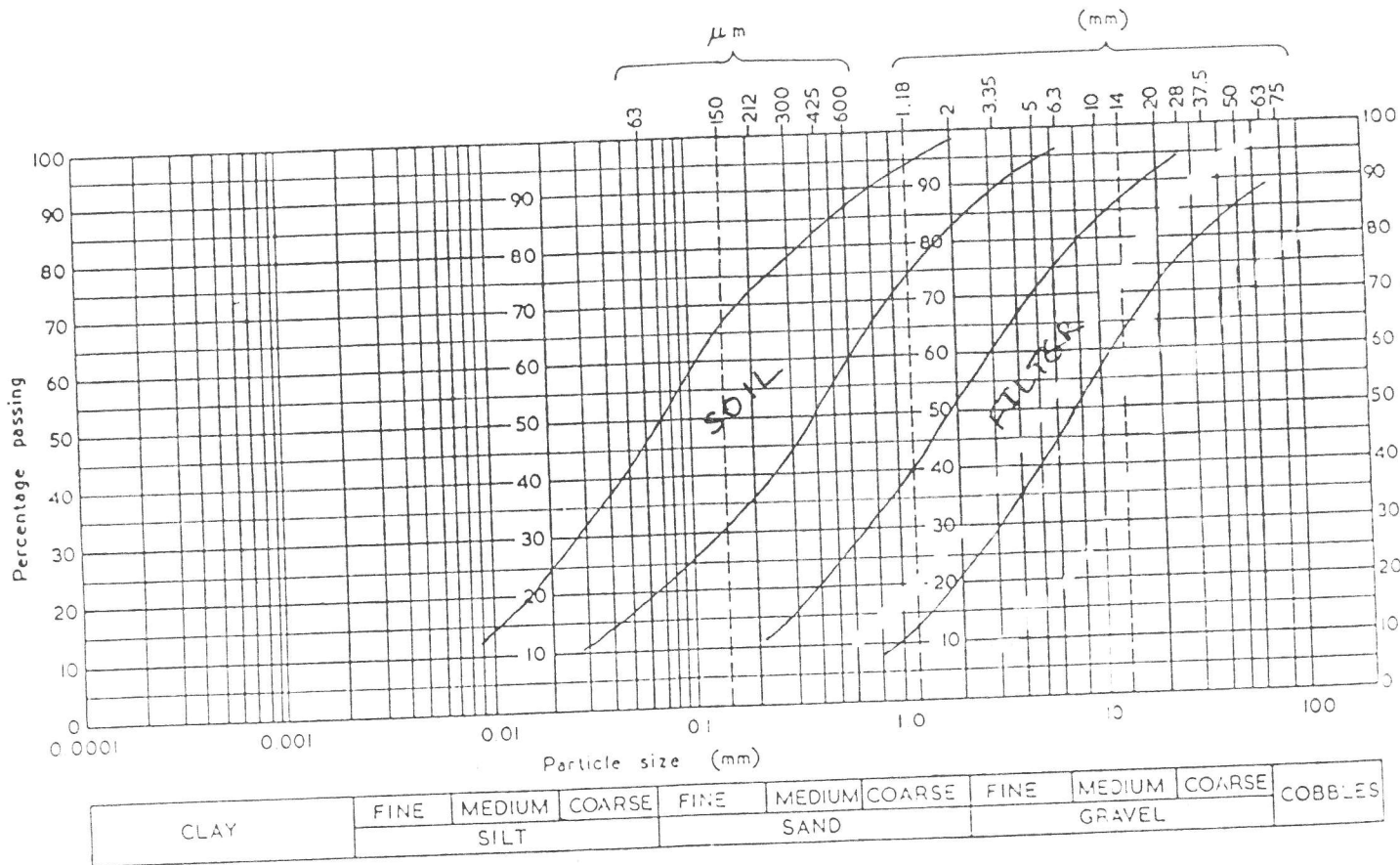

Figure 5.2 TYPICAL SOIL AND FILTER GRADINGS



6 STRUCTURAL DESIGN

6.1 General

The loadings and structural design for a gallery constructed of masonry walls with reinforced concrete floor and roof slabs are discussed in this Chapter. An example of the structural calculations are given in the worked example in **Appendix A**. The design of other types of gallery, particularly for a reinforced concrete box culvert type gallery, would be very similar. The design of a reinforced concrete pipe type culvert is not covered here, whilst the design of a galvanized steel pipe type gallery is covered in the manufacturer's literature.

The final part of this Chapter discussed the bedding details required for the outlet pipes from the galleries.

6.2 Roof

It has been found that the worst case loading conditions for a gallery are when the gallery is under its maximum design flood, taken as a 1 in 50 year flood event in this Manual. The depth of water above the bed level for a 1 in 50 year flood will first therefore have to be determined.

The forces on the gallery are shown on **Figure 6.1**. The vertical forces on the gallery top slab comprise three components:

- i. The water pressure (p_w) on the slab due to the depth of water above the slab:

$$p_w = h_2 \rho_w g \quad [\text{N/m}^2]$$

Where:

$$\rho_w = \text{density of water [1,000 kg/m}^3\text{]}$$

$$h_2 = \text{height from top of flood water level to the roof of the gallery [m]}$$

$$g = \text{gravitational constant [9.81 m/s}^2\text{]}$$

Note: 1 kg exerts a force of 9.81 N.

- ii. The submerged weight of soil (p_s) which is due to the weight of soil less the hydrostatic uplift:

$$p_s = h_1 \rho' g \quad [\text{N/m}^2]$$

Where:

$$\rho' = \text{submerged density of the soil } (\rho_s - \rho_w) \text{ [kg/m}^3\text{]}$$

$$h_1 = \text{depth from river bed level to the gallery roof [m]}$$

- iii. The self weight of the roof slab (p_r):

$$p_r = t \rho_c g \quad [\text{N}]$$

Where:

$$\rho_c = \text{unit weight of concrete [about 2,400 kg/m}^3\text{]}$$

$$t = \text{the thickness of the roof slab [m]}$$

The pressures are converted to forces per unit length of gallery by multiplying by the width of the gallery roof slab. The total load on the roof slab is then the sum of the above three forces. Usually this force is multiplied by a load factor of around 1.4 as a factor of safety.

The roof slab is considered to be simply supported on the side walls. The vertical load acting from the roof to the walls and vice versa is half the total load on the roof slab on each wall.

The roof slab may now be designed according to conventional reinforced concrete design practice.

6.3 Walls

The lateral forces acting on the walls are greatest at the base of the walls, and are shown on **Figure 6.1**. These lateral forces comprise three components:

i. Hydrostatic pressure at bed level = $h_4 \rho_w g$ [N/m²]

Where:

$$\begin{aligned} \rho_w &= \text{density of water [1,000kg/m}^3\text{]} \\ g &= \text{gravitational constant [9.81 m/s}^2\text{]} \\ h_4 &= \text{height of water above bed level during design flood [m]} \end{aligned}$$

ii. Effective earth pressure = $K_o h_3 \rho' g$ [N/m²]

Where:

$$\begin{aligned} K_o &= \text{coefficient of static pressure} = 1 - \sin \Phi \\ \rho' &= \text{submerged density of the soil } (\rho_s - \rho_w) \text{ [kg/m}^3\text{]} \\ h_3 &= \text{depth of soil to base of gallery from the river bed [m]} \\ \Phi &= \text{shear strength of the soils.} \end{aligned}$$

For cohesionless soils, Φ may be taken as:

Sandy gravel	35° to 40°
Compacted sand	35° to 40°
Loose sand	30° to 35°
Shale filling	30° to 35°
Rock filling	35° to 45°

iii. Additional hydraulic pressure = $h_3 \rho_w g$ [N/m²]

Where:

$$\begin{aligned} \rho_w &= \text{density of water [1,000kg/m}^3\text{]} \\ h_3 &= \text{depth from river bed level to base of gallery [m]} \end{aligned}$$

The total lateral design pressure acting at the base of the walls is the sum of the above three pressures, multiplied by the load factor of 1.4. The walls are also subjected to vertical loads on the top and bottom from the roof slab and the floor slab respectively. These loads tend to prestress the walls.

The mode of structural failure of the walls is most likely to be in shear resulting from the lateral forces. Therefore an allowable characteristic shear strength needs to be calculated and compared with the shear resulting from the design conditions. From this, the optimum block size is found.

Allowable Shear Stress

BS 5628:Part1 Chapter 25⁹, defines the characteristic shear strength, f_v , of masonry as:

$$f_v = 51 + 0.6G_a \quad [\text{lb/inch}^2]$$

In metric units,

$$f_v = 36,000 + 0.6G_a \quad [\text{kg/m}^2]$$

Where:

G_a = design vertical load per unit area of cross-section ($= P / t_w$) [kg/m²]

P = the vertical reaction of the wall against the floor slab [kg]

t_w = the thickness of the wall [m]

The allowable shear stress = $f_v / 2.5$

Where 2.5 is a partial safety factor for masonry strength in shear. When considering the likelihood of misuse or accident the value may be reduced to 1.25.

Actual Shear Stress

The actual shear stress for the design conditions is then calculated as follows per unit length of gallery:

Shear force (F) = pressure at base of wall * $H / 2$ [N/m length of gallery]

and

Shear stress = $F / (t_w)$ [N/m²]

Where:

F = shear force [N/m length of gallery]

H = height of the wall [m]

t_w = thickness of the wall [m]

If the actual shear stress exceeds the allowable shear stress then the thickness of the wall t_w should be increased.

In the design of the masonry gallery shown on **Figure 6.2**, the shear at the junction between the walls and the roof and floor slabs is also resisted by the downstand from the roof slab and the insitu concrete channel insert in the base slab.

^{9/}

6.4 Floor

The vertical forces on the floor slab comprise two components:

- i. The uplift water pressure on the slab.

$$p_w = (h_3 + h_4) \rho_w g \quad [\text{N/m}^2]$$

Where:

$$\begin{aligned} \rho_w &= \text{density of water [1,000kg/m}^3\text{]} \\ h_3 + h_4 &= \text{height from top of flood water level to base of floor [m]} \end{aligned}$$

- ii. The vertical forces transmitted from each wall:

$$F = N + w \quad [\text{N per m length of gallery}]$$

Where:

$$\begin{aligned} N &= \text{vertical load on each wall from the roof [N per m length of gallery]} \\ w &= \text{weight of one wall [N per m length of gallery]} \end{aligned}$$

Next the bearing pressure needs to be calculated to see if it exceeds the allowable bearing capacity of the gallery foundation. The following equation assumes that the force F spreads out to cover the whole of the base.

$$\text{Bearing pressure} = 2F / w' - p_w \quad [\text{N/m}^2]$$

Where:

$$\begin{aligned} F &= \text{vertical force on floor from one wall [N per m length of gallery]} \\ p_w &= \text{uplift water pressure on floor [N/m}^2\text{]} \\ w' &= \text{width of base slab [m]} \end{aligned}$$

Indicative values of safe bearing capacities for various soils are given in Section 3.6 of Part 1: Site Investigations, and duplicated below for non-cohesive soils.

Non-cohesive Soils	(KN/m ²)	(tonnes/m ²)	
Compact gravel or sand well cemented	540 to 780	55 to 80	Providing the width of the footing (B) is not less than 1m, and the groundwater level is more than B below the base of the footing.
Compact gravel or sand and gravel	420 to 540	43 to 55	
Loose gravel or sand and gravel	290	30	
Compact coarse sand (confined)	440	45	
Loose coarse sand	200	20	
Loose fine sand	100	10	
Sand with clay	200	20	
Kankar	310	32	c156B

Notes:

1. The values given in the table are only approximate, and the allowable bearing pressure for individual soils may differ considerably. The figures have a factor of safety of 2 to 3.
2. If the groundwater level in sand or gravel soils is likely to approach foundation level the safe bearing capacity should be reduced to about one-half of the values given.
3. The safe bearing capacity can be exceeded where the foundation is taken well down into the ground by an amount equal to the weight of the material which is displaced by the foundation itself.

6.5 Outlet Gate

The gate on the outlet of an infiltration gallery will typically be a slide gate with a screw hoist for opening and closing it from the manhole roof. The screw hoist is required for closing since the gate is so small that it cannot be guaranteed to fully close under its own weight. The basic principles for design of the gate itself are the same as those described in Chapter 7 of Part 2: Weir Design.

6.6 Outlet Pipe Bedding

The load bearing capacity of a concrete pipeline is dependent both on the strength of the manufactured pipe and on the support provided by the bedding. For most pipes, buried 3ft or 4 ft below the ground level, the bedding conditions of the pipe are often not critical. However, the discharge pipe from a gallery is often buried at considerable depth and the bedding detail for the pipe must therefore be considered.

The bedding factor F_m is a numeric description of the degree of support provided by different types of pipe bedding. The higher the bedding factor, the greater is the load-carrying capacity of a given pipeline. The types of bedding normally used with concrete pipes are shown on Figure 6.3. The three most common bedding types are:

	Bedding Factor
Class B (180 degrees granular bedding)	1.9
Class S (360 degrees granular bedding and surround)	2.2
Class A (plain concrete cradle)	2.6

Figure 6.4 gives the appropriate class of bedding to be adopted for class M pipes buried at different depths. The table has been developed using criteria developed by BRE¹⁰ and should only be under the following conditions:

- for concrete pipes equivalent or stronger than Class M;
- where the density of backfill is less than or equal to 125 lb/ft³; and,
- where traffic load on the trench is very light, as appropriate to field conditions.

¹⁰

BRE "Simplified Tables of External Loads on Buried Pipelines" Building Research Establishment, UK.

6.6.1 Granular Bedding

Non compressible free-draining materials should be used, for example gravel or crushed stone, that are evenly distributed and correctly graded in accordance with the following table:

NOMINAL PIPE DIA	PIPE BEDDING REQUIREMENT
6 inch	0.4 or 0.5 inch nominal single size or 0.5 to 0.2 inch graded.
9 to 20 inch	0.4, 0.5 or 0.8 inch nominal single-size or 0.5 to 0.2 inch graded or 0.8 to 0.2 inch graded
≥ 24 inches	0.4, 0.5, 0.8 or 1.6 inch nominal single-size crushed rock or 0.5 to 0.2 inch graded or 0.8 to 0.2 inch graded or 1.6 to 0.2 inch graded.

Where the pipeline is laid in wet soils, the bedding material should be surrounded with a geotextile filter fabric to minimise migration of fines from the trench walls.

6.6.2 Concrete Bedding

Minimum strength concrete of 20 MN/m^2 ($2,900 \text{ lb/inch}^2$) at 28 days (equivalent to BCIAP concrete class B) is essential to provide uniform and adequate support. Sufficient time must be allowed for the concrete to gain strength before being subjected to compaction, traffic or backfill loading.

Pipeline flexibility must be retained by leaving gaps at pipe joints filled with soft compressible material. Good trench foundations are also important to reduce shear at the points where these gaps occur. Additional strength can be obtained by using reinforced concrete.

Figure 6.1 LOADINGS ON GALLERY

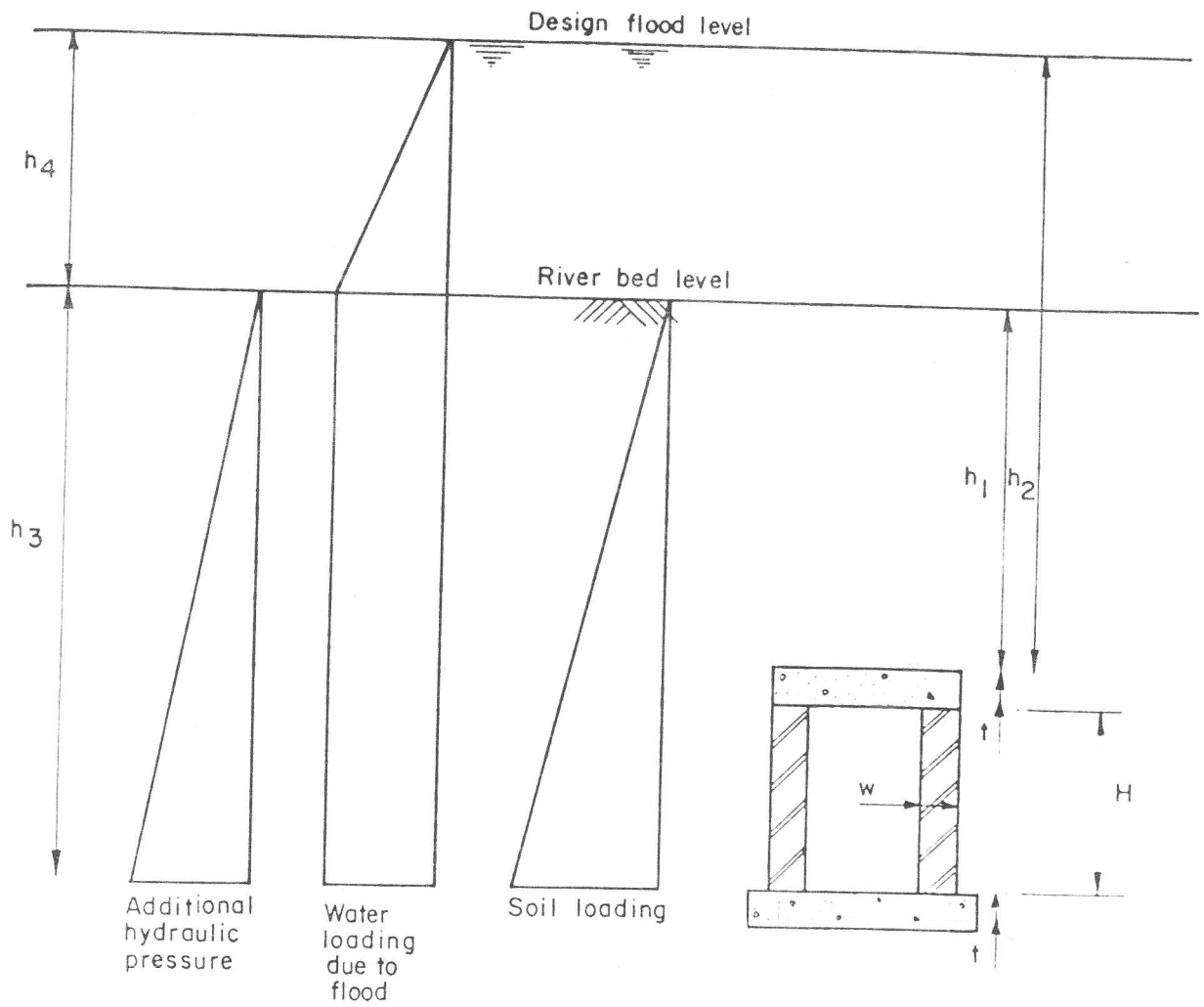

Figure 6.2 TYPICAL GALLERY CROSS-SECTION

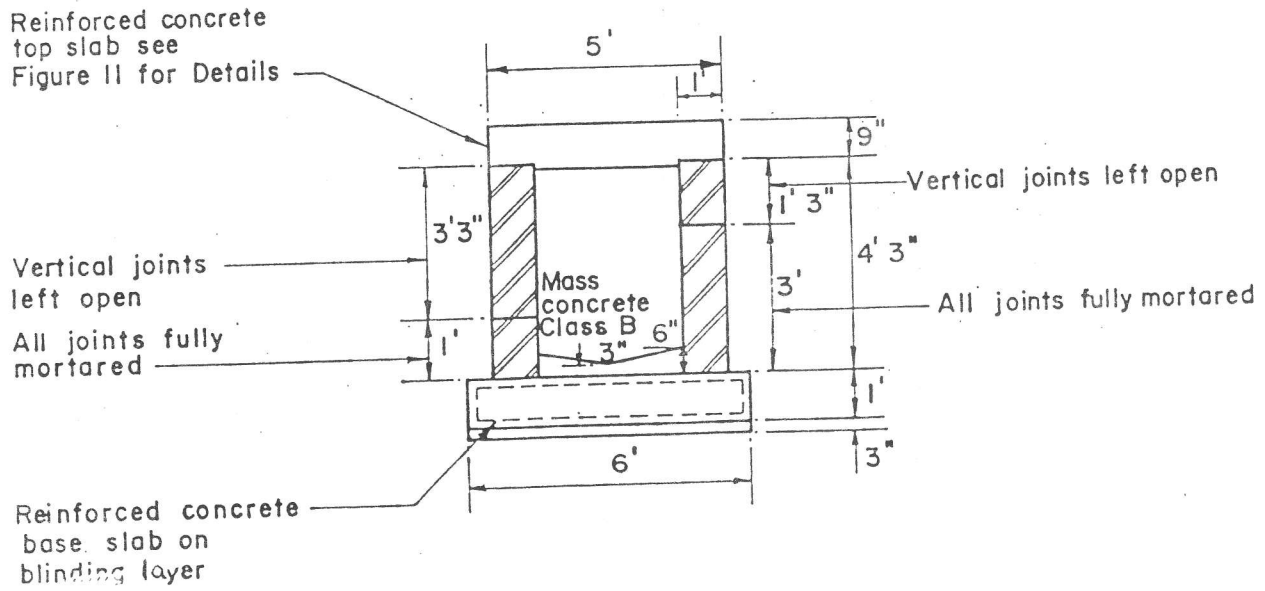
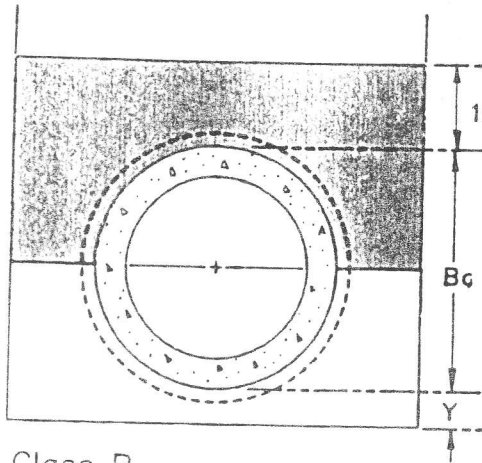
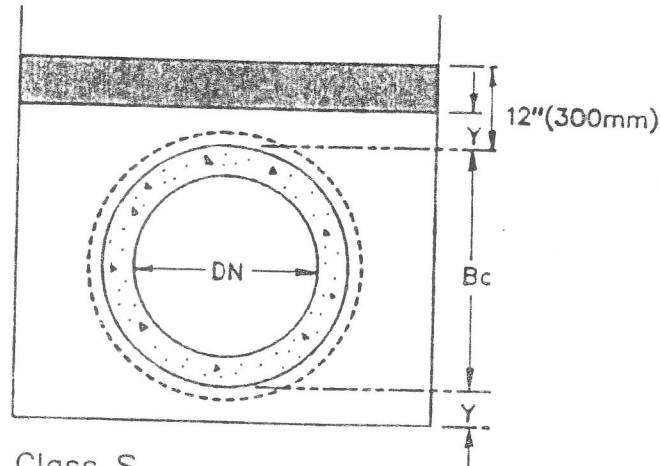

Figure 6.3 BEDDING DETAILS AND FACTORS

GRANULAR BEDDING



Class B
180 Granular Bed
Fm - 1.9



Class S
360 Granular Bed and Surround
Fm - 2.2

CONCRETE BEDDING

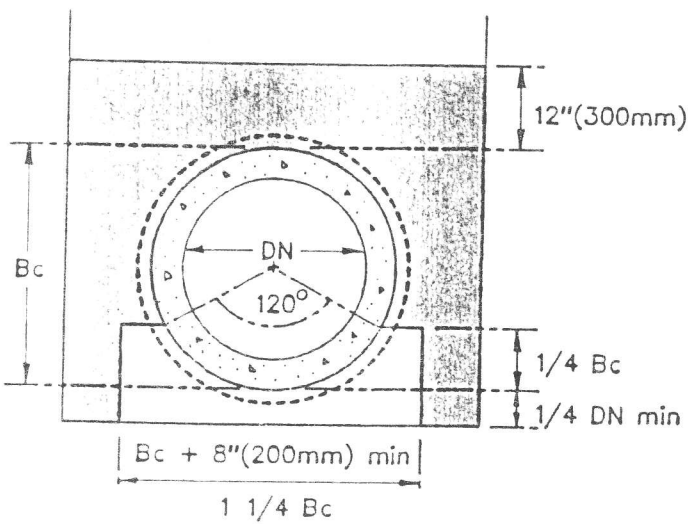

Class A
120 Concrete Cradle
Plain Concrete Fm - 2.6

- Granular Bedding Material
- Selected Backfill Material
- In-situ Concrete

Notes:

1. Bedding beneath and at sides of pipe to be well compacted.
2. Bedding/backfill directly above the pipe to be lightly compacted by hand.
3. Dimension Y: $1/6 B_c$, or 4" (100mm) under barrels, and 2" (50mm) minimum under sockets whenever is and greater (16" (400) max). Rock etc. $1/4 B_c$ and 6" (150mm) minimum under sockets (16" (400) max).

Figure 6.4 CHART OF PIPE BEDDING IN RELATION TO DEPTH

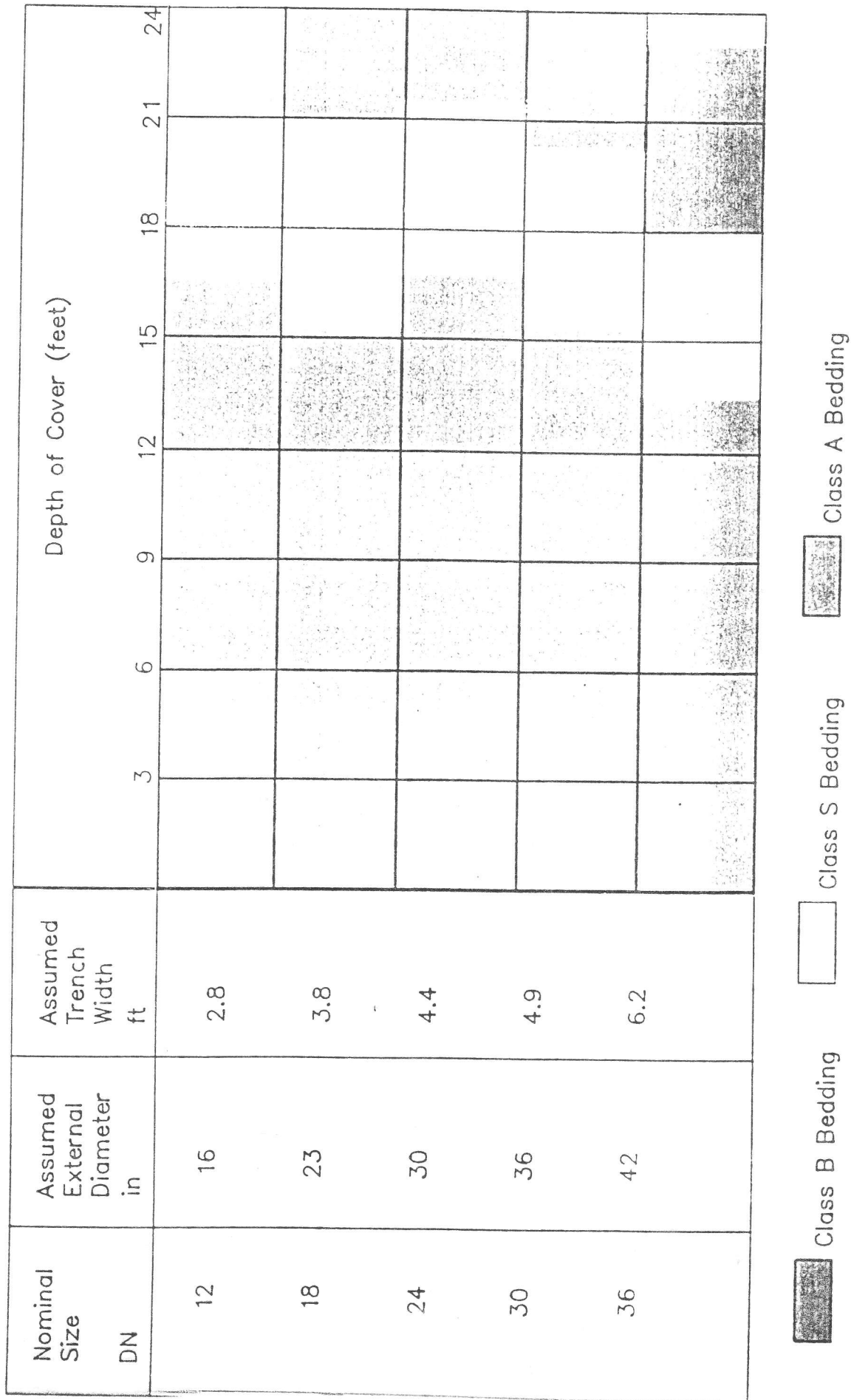

APPENDIX A
WORKED EXAMPLE

BIBLIOGRAPHY

- Bennett, TW "The Design and Construction of Infiltration Galleries." Groundwater, Vol 8., No. 3, 1970.
- Bouwer, H "Groundwater Hydrology" McGraw-Hill Book Company. 1978.
- British Standards Institute BS 5628, "Code Of Practice For Use Of Masonry, Part 1, Structural Use of Unreinforced Masonry."
- Building Research Establishment "Simplified Tables of External Loads on Buried Pipelines." BRE, UK
- Hanson, G & Nilson, A "Ground Water Dams for Rural Water Supplies in Developing Countries." Ground Water Magazine, July-August 1986
- HRL "Tables for the Hydraulic Design of Channels and Pipes." Hydraulics Research Ltd, UK.
- Huisman, L "Groundwater Recovery." Macmillan, 1972.
- ILRI "Drainage Principles and Application, Volume 4: Design and Management of Drainage Systems." International Land Reclamation Institute, Wageningen, The Netherlands. 1980.
- Kruiseman, GP & de Ridder, NA "Analysis and Evaluation of Pumping Test Data." International Institute for Land Reclamation, Wageningen, the Netherlands. 1979.
- Neil, CR "Guide to Bridge Hydraulics.", University of Toronto Press. 1973.
- USBR "Design of Small Dams." United States Bureau of Reclamation. 1977.
- USBR "Hydraulic Design of Stilling Basins and Energy Disipators." United States Bureau of Reclamation. 1983.
- US Department of the Interior "Groundwater Manual." 1981.
- Withers, B & Vipond, S "Irrigation Design and Practice." BT Batsford Ltd, 1974.